

0302 (E) - AA

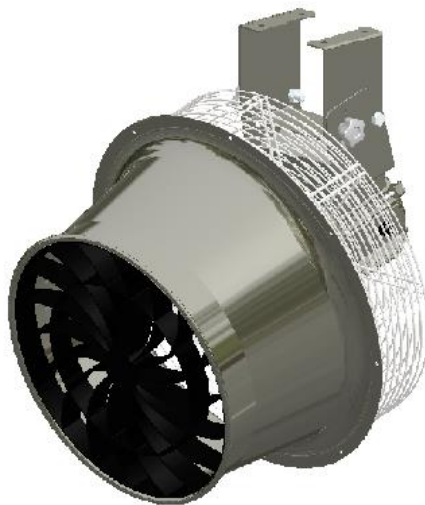

# Instruction Manual



**SDG**

## Introduction



Thank you for the purchase of the Windracer.

Please read the following instructions and warnings carefully (especially the sections marked with ) and use the Windracer safely and effectively.

**Please keep these Operating Instructions and Warnings at hand for your later reference.**

About the marks that appear in this book

The marks that appear in this book have the following meanings.

 <b>WARNING</b>	Symbolizes that in case of making a wrong use of the system, there is a chance of dying or getting severely injured.
 <b>CAUTION</b>	Symbolizes that in case of making a wrong use of the system, there is a chance of causing wounds or material damage.

### Meaning of warning symbols

**Strictly observe the indicated cautionary notes and instructions.**



LK011

Prohibited

(applicable to all items)



LK021

Perform as

instructed



LK031

Take measures to

prevent danger



LK041

Beware of danger

(applicable to all items)



LK013

Disassembly

prohibited



LK033

Caution against

electric shock

## 1. Safety warnings

# WARNING



LK011

### **Never operate the product in a dangerous environment.**

The Windracer is not explosion-proof. Never operate the Windracer in an explosive environment (place where an explosive gas exists/generates or may exist/generate). Explosive gases present at the installation site can trigger an explosion and create a dangerous situation in the event a spark is generated by damaged motor (heat seizure), by friction caused by foreign items entered in the product, or by plugging/unplugging of the power cord.



LK011

### **Note regarding intake air**

Use the Windracer only to suck in air. Corrosive gases such as acidic or alkaline gases can significantly shorten the service life of the Windracer. If a solid object enters the Windracer, the entered object and/or Windracer can break, and broken pieces can eject and injure people near the Windracer. It also leads to product damage. Mixing of powders or liquids (mist and steam) can also damage the product.



LK021

### **Prevention of electric shock, etc.**

Check the power source current and voltage indicated on the product nameplate. Be sure to connect the Windracer to a power supply with an appropriate capacity.



LK011

To prevent damage to the power cord and its connecting section on the main unit, observe the following:

- Do not forcibly bend or twist the power cord.
- Do not place any heavy item on the power cord.
- Do not heat the power cord.
- Do not disconnect the power cord from the power outlet by pulling a section of the cord other than the plug.
- Do not move the main unit by pulling the power cord.
- Do not unplug the power cord from the power outlet with a wet hand.



LK021

Do not turn the power switch ON and OFF repeatedly within a period of one minute. Doing so can cause heat seizure damage to the motor.



LK021

Install a main power ON/OFF switch or circuit breaker as needed.



LK031

Do not touch the switch with a wet hand.



LK011

**Keep your face away from around the discharge port.**

Small dust, etc., taken in by the blower may rush out of the discharge port at a high speed. If such dust enters the eye, accidents such as loss of eyesight may occur. Make sure to keep your face away from around the discharge port.



LK013

**Do not detach the guard screen.**

Never operate the Windracer without the guard screen on the casing (product body). If a hand is inserted into the Windracer, the fingers or wrist

can be injured. Do not dismount the guard screen except when cleaning the product or conducting maintenance/inspection.



LK011

**Do not insert fingers through the wire screen when the Windracer is operating.**

Do not insert fingers through the wire screen when the Windracer is operating.



LK021

**Note regarding installation**

Install the Windracer on a vibration-free, solid frame. Make sure that the Windracer is installed securely without any looseness.

\* Tighten the bolts and nuts firmly.

If the Windracer is installed at a high place, secure it with a wire or chain to prevent it from falling.



# CAUTION



LK021

**Note regarding the air angle adjustment knob**

The Windracer is provided with a manual air angle adjustment knob. If the knob becomes loose due to vibrations or other causes, use the supplied bolts and nuts, instead of the base (air angle adjustment knob), for secure attachment.



LK031

**Do not splash water on the Windracer.**

The Windracer is not water-/drip-proof. Do not splash water on the Windracer. Water can damage the motor and also cause rusting.



LK011



LK011

**Note regarding allowable intake air temperature/humidity**

- Allowable intake air temperature: -5°C to 40°C
- Allowable humidity: Less than 90% in relative humidity, without dew condensation (water droplets)

## 2. Parts name of product

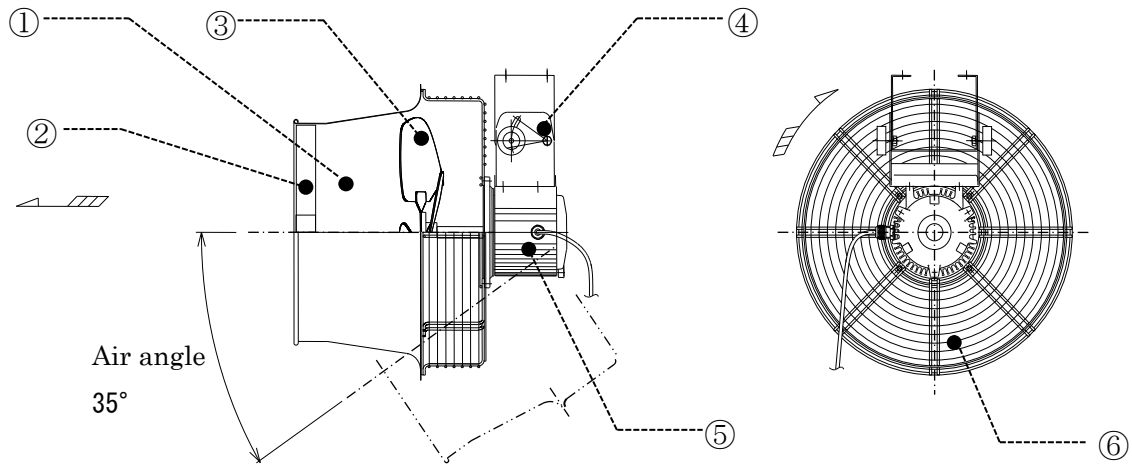

\* For 3 Phase motors, terminal box is attached instead of lead wire.

- (1) Casing    (2) Guide Vane    (3) Impeller    (4) Mounting fixture  
(5) Motor    (6) Guard screen

## 3. At the time of receipt

### 3. 1 Product check at the time of receipt

Although we only ship products that have passed an intensive exam, we ask you to check the following points at the time of receipt.

- \*Does the fan match the model you ordered?
- \*Is there any abnormality (damage or deformation) caused during the delivery?
- \*Is there any loosening on the bolts or nuts?

### 3. 2 Cautions in unpacking and installing the product

**Do not hold the Windracer by the guard screen.  
The wire net of the guard screen can be easily deformed  
if it is grasped by hand.**

## 4. Operation, maintenance and inspection

Periodic maintenance and inspection are required to operate the blower safely. If the daily inspection is performed on the following items and the results are recorded, abnormalities can be detected early to prevent problems.

An experienced person or a trained person confirms security, and, please carry out the maintenance check. Please carry it out about the motor by the instruction manual of the motor.

Inspection item		Recommended inspection cycle			Inspection contents	
		3 months	6 months	12 months		
Condition inspection	Abnormal noise	Blower	■	□	□	Check for abnormal noise due to rattles. Check for metal contact noise. Check for other noise considered to be abnormal.
		Motor	■	□	□	Check the grease. Check for loose bolts.
	Vibration		■	□	□	Check the vibration value and any changes to it.
	Electrical section		□	■	□	Check the current value and voltage value, and any changes to them.

## 5. Spec of motor

Please refer to name plate stuck on the motor.

## 6. Attention for 3 Phase motor type

- Electric wiring should be operated by licensed person comply with local codes of indoor wiring and electric installation rules.
- At the trial running, please switch on once and immediately turn off it and check the rotation direction of impeller.  
If the rotation direction is opposite, cut the power supply and change the position of 2 of 3 power supply codes.

## 7. Warranty

### Scope of warranty

Repair service is provided free of charge for a failure during the warranty period, as long as the blower has been used in compliance with these Operating Instructions, labels attached to the body, and other instructions.

In the case that this product is incorporated into other equipment used by the customer, the warranty does not cover costs for removal from such equipment, reattachment to such equipment, costs of other incidental work, costs of transportation etc., resulting opportunity loss incurred by the customer, lost operation, or any other indirect loss or damage suffered by the customer.

- For requests for repair service, please contact our nearest branch or sales office.

### Warranty period

One (1) year from the date of delivery of the product.

### **Even during the warranty period, only charged service is provided in principle, if any of the following applies:**

- Failure or damage due to incorrect use that is not compliant with these Operating Instructions, labels attached to the body, or other instructions, and/or unauthorized repair or modification
- Failure or damage due to transportation, dropping, etc. after the purchase
- Failure or damage due to fire, earthquake, storm, flood, lightning or other natural disasters, environmental factors such as salt damage and public pollution, abnormal voltage, use of a power supply (voltage or frequency) other than that specified, or the like
- Failure or damage due to repair or modification (including punching, etc. in the product) not conducted by our company
- Failure or damage due to the use of parts other than those designated by our company
- Failure or damage due to the entry of foreign material
- Discoloration, scratching, natural consumption of consumable parts or other defects due to use or deterioration over time
- Failure or damage caused by neglecting the maintenance and inspection described in the Operating Instructions

### **We will not compensate for any loss or damage resulting from defects that occur during the use of this product.**

[Notices]

- (1) The descriptions in these Operating Instructions are subject to change without prior notification in the future.
- (2) We have made all possible efforts to prepare these Operating Instructions. However, if you have any questions about them or find any inquiries, errors, omissions, etc., please contact our nearest branch or sales office.
- (3) If the power supply frequency changes due to a change in the location where the blower is used, it may not be used as it is. We will consider a measure in each case where it is required. In such a case, please contact our nearest branch or sales office.
- (4) At the time of inquiry, please describe the product type and the manufacturing number indicated on the product nameplate.



1-25 Shinden, Kita-machi, Daito City, Osaka 574-0052, Japan

---

Oversea Sales Engineering Department

1-25 Shinden, Kita-machi, Daito City, Osaka 574-0052

Tel+81(72871) 1511 Fax+88(72870) 7243

SDG(THAILAND)CO., LTD.

No. 71 Soi Chalermprakit Rama 9 Soi 28, Dokmai, Prawet, Bangkok, Thailand 10250

Tel+66 (2330) 8798 Fax+66 (2330) 8799

SDG(KOREA)CO., LTD.

31094 A-710 Cheonan Mirae Ace High Tech City, 10, Baekseokgongdan 1-ro, Seobuk-gu, Cheonan-si, Chungcheongnam-do, Korea

Tel+82(41906)5710 Fax+82(41906)5720

SDG(TAIWAN)CO., LTD.

No.82, Liaoyang 4th Street, Beitun Dist., Taichung City 406, Taiwan

Tel+886(42241)3005 Fax+886(42241)3006

---

<https://www.sdg-eng.com>

