

ヒュームコレクタ Fume Collector

取扱説明書 Instruction Manual

型式／MODELS

CBA-1000AT3-HC-DSA-V1	(100V)
CBA-1000AT3-HC-DSA-V1-T	(200V)
CBA-1000AT3-HC-DSA-V1-CE	(220-230V)



- 取扱説明書(以下、本書といいます)の『製品使用上のご注意』の内容をよく理解し、本書をよく読んでから操作してください。
Please understand well the contents of "Cautions on Product Use" of Instruction Manual (hereinafter referred to as "this manual"), and operate it after often reading this manual.
- 本書はいつでも使用できるよう、大切に保管してください。
Please keep this manual carefully to be able to use it at any time.

■はじめに／Introduction

このたびは、お買い上げ頂き、誠にありがとうございます。

チコーエアートック株式会社は「風の技術」を有効に利用し、コンパクトに空気をクリーンにすることをテーマとして努力しております。

この製品は、この風の技術に消臭機能を付加し、コンパクトにまとめた省エネ形のクリーン BOX です。

長期間故障なく安全にご使用いただくために、この取扱説明書をよくお読みいただき、本機の性能を十分に発揮できますよう正しいお取扱いをお願いします。

We greatly appreciate that you have purchased our dust collector.

CHIKO AIRTEC CO., LTD. is working to achieve clean air with compact equipment while utilizing "air technology" effectively.



This machine is an energy-saving-type clean box that realizes "air technology" in a compact body.

Please read this instruction manual thoroughly and handle this machine correctly so that you can use it safely for a long time and enjoy its full performance.

■本文中の表記について／About Notation

本書では、以下の表記に従って説明しています。

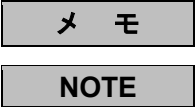
This manual explains according to the following notations.

表記／Notation	意味／Description
	本機の機能を十分に発揮するための情報や、本機の損傷を防ぐための情報を記載しています。 The information for fully exhibiting the function of this machine and the information for preventing damage to this machine are indicated.
	参考となる情報を記載しています。 The information which is consulted is indicated.
1. 2. 3. ...	操作手順を記載しています。 The operating procedure is indicated.
	参照先を記載しています。 The reference destination is indicated.

■転載・複写について／Copyrights

- 本書の著作権は、チコーエアートック株式会社が所有しています。
CHIKO AIRTEC CO., LTD. owns the copyright of this manual.
- 本書の内容の一部あるいは全部の無断転載や複写は固くお断りします。
Unauthorized reproduction or copying of part or all of the content of this manual is strictly prohibited.
- 本書の内容は、将来予告なく変更することがあります。
The contents of this manual are to change without notice.

Contents

Chapter 1 Product Usage Precautions	3
1.1 Safety Notations	3
1.2 Precautions for Transport, Storage, and Relocation.....	3
1.3 Precautions for Installation	3
1.4 Precautions for Operation	4
1.5 Other Precautions	4
1.6 Safety Label Locations	5
Chapter 2 Components Identification	6
2.1 Accessories	6
2.2 Device Body	7
2.2.1 CBA-1000AT3-HC-DSA-V1	7
2.3 AT3 Panel	8
2.4 Display Indications	9
2.4.1 About Modes.....	9
2.4.2 While Stopped	9
2.4.3 Indications During Operation.....	10
Chapter 3 Operation	11
3.1 Start-up Preparation	11
3.1.1 Installation	11
3.1.2 Wiring and Piping	13
3.2 Operation.....	13
3.3 Registering Initial Pressures	14
Chapter 4 Configuring Settings (MODE SELECT Mode)	15
4.1 Screen Transitions in MODE SELECT Mode.....	15
4.2 Shaking Setting mode	15
4.2.1 Shaking manual setting mode.....	15
4.2.2 Shaking time setting mode.....	16
4.2.3 Interval time setting mode for Auto shaking	16
4.3 Communication Format Setting Mode (When Equipped with Communication Function)	17
4.4 Air Volume-Down Alert Timing Setting Mode	17
4.5 Other Setting Mode	18
4.5.1 Clock Calibration Mode	18
4.5.2 Accumulated Run Time Reset Mode.....	18
4.5.3 Setpoint Reset Mode	19
4.6 Error History Mode	19
Chapter 5 Maintenance and Checkup	20
5.1 Replacing Filters.....	20
5.1.1 Replacing the Primary Filter	20
5.1.2 Replacing Secondary Filter	21
5.1.3 Replacing the Exhaust Filter	21
5.2 Replacing Fuse.....	22
5.3 Replacing the Button Battery	23
5.4 Daily Inspection	23
5.5 Errors/Warnings.....	24
5.5.1 Action on Errors/Warnings.....	24
5.5.2 Error / Warning Table.....	25
5.6 Troubleshooting.....	26
Chapter 6 Useful Utilization (Optional)	27
6.1 Remote Cable.....	27
6.1.1 Electrical Diagram	27

6.1.2 Pin Assignments	29
6.1.3 Remote Operation	30
6.2 Communication Function.....	30
6.2.1 RS485 Communication	30
6.2.2 Ethernet	30
6.3 Removable Flange.....	30





Chapter 7 Appendix 31

7.1 Specifications	31
7.2 Consumables List.....	31
7.3 Electrical Diagram	32
7.3.1 CBA-1000AT3-DSA-HC-V1.....	32





Chapter 1 Product Usage Precautions

1.1 Safety Notations





This instruction manual describes usage precautions with the below listed symbols. Be sure to read the instructions.

Symbol	Meaning
 WARNING	Indicates a hazardous situation which, if not avoided, could result in personal death or serious injury.
 CAUTION	Indicates a hazardous situation which, if not avoided, could result personal injury or damage to the device.
	Indicates a prohibited action (which MUST NOT be done).
	Indicates a mandatory action (which MUST be done).







1.2 Precautions for Transport, Storage, and Relocation

 WARNING		<ul style="list-style-type: none"> Transportation must be done using at least two people. Injury may result due to fall hazard.
 CAUTION		<ul style="list-style-type: none"> Relocation and storage must be done in a safe location within the temperature range of -10°C to 60°C at relative humidity of 80% or less.





1.3 Precautions for Installation

 WARNING		<ul style="list-style-type: none"> Do not install the device in or around an area with flammable, explosive, or corrosive mist, smoke, or gases.
 CAUTION		<ul style="list-style-type: none"> This device is designed for installation in a cleanroom or a clean factory. Avoid installation in other areas, such as outdoors. Ensure a wide suction port. If the device is used continuously with a narrow suction port (i.e., at high pressure), the motor may become hot as it cannot be cooled.
		<ul style="list-style-type: none"> Install the device in a horizontal, vibration-free location as it contains rotating equipment. Install the device at normal temperature (ambient temperature 0°C to 40°C, at humidity 80% or less) without dew condensation. High temperature or dew condensation may cause failure of electrical components or electric shock. Beware that suction ambient temperature (temperature around the dust to be collected) is low enough, because otherwise the motor may lead to performance reduction or failure. Provide a sufficient space for the exhaust port (at least 100 mm from the exhaust port). If the exhaust port is blocked, the proper suction power cannot be delivered. Furthermore, sufficient cooling is not provided in the box, causing burnout of the motor or failure of electrical components. The installation site should be at an altitude of 1,000 m or less.

1.4 Precautions for Operation

 WARNING		<ul style="list-style-type: none"> Do not suck the following substances: Flammable substances... Gasoline, thinner, benzene, kerosene, paints, etc. Explosive dusts Aluminum, magnesium, titanium, zinc, epoxy, etc. Sparky dust Dust containing sparks from high-speed cutting machine, grinder, welding machine, etc. Fire source Cigarette, and liquid such as oil and chemical Others..... Liquid such as water, oil, chemical Do not use the device in or around an area with flammable, explosive, or corrosive mist, smoke, or gases. Ensure secure connections, without bending or pulling cables with excessive force. Fire or electric shock may result. Ensure that the power supply conforms to the specifications of the device.
		<ul style="list-style-type: none"> Use the device to suck dry dust without potential dust explosion. Be sure to connect the ground wire.
 CAUTION		<ul style="list-style-type: none"> Do not move the device while in operation.
		<ul style="list-style-type: none"> Use the device in locations of pollution degree 2. Use a power supply of overvoltage category II. Turn off the main power switch in case of power outage. Injury or device damage can occur when power returns. Ensure that filters are installed correctly. If filters are missing, clogged, or broken, foreign matter may enter the motor, causing failure.

1.5 Other Precautions

 WARNING		<ul style="list-style-type: none"> Do not disassemble or alter the device. Failure to observe can cause electric shock or injury. For internal checkup or repair, contact your dealer.
		<ul style="list-style-type: none"> Follow the information in the instruction manual when performing installation, connection, starting, operation, checkup, and fault diagnosis. Working in a wrong manner may lead to fire, electric shock, or injury.
 CAUTION		<ul style="list-style-type: none"> When discarding the device, dispose of it appropriately as an industrial waste.

1.6 Safety Label Locations

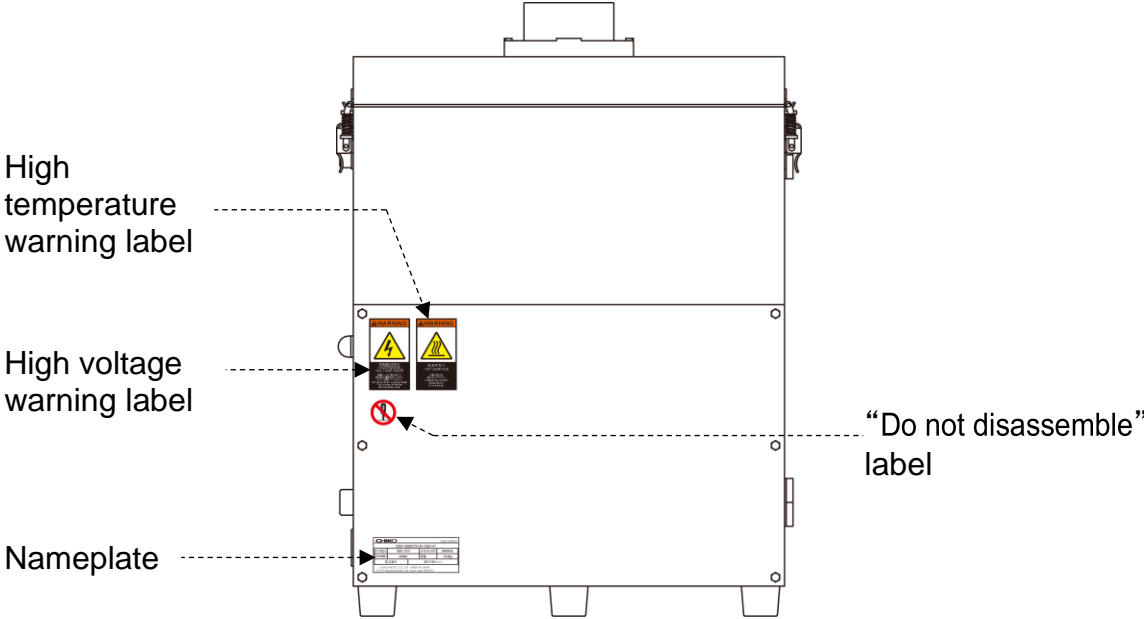

High voltage warning label

High temperature warning label

"Do not disassemble" label

Name plate

⚠ WARNING

危険電圧部有り
HAZARDOUS
VOLTAGE INSIDE

感電による火傷や死亡の
恐れ有り。電源を切ってから、
カバーを開いてください。
Can shock, burn or cause death.
Turn power off before
removing the cover.

⚠ WARNING

高温部有り
HOT SURFACE

火傷の恐れ有。
触らないで下さい。
Contact may result in
Severe burns.
Do not touch.



CHIKO Dust Collector

--**-***

Voltage	*** V	Frequency	*/ * Hz
Current	*. * A	Mass	*. * kg
SERIAL NUMBER	20***-***-***		

CHIKO AIRTEC CO., LTD MADE IN JAPAN
2-27-24 Hakushima, Minoh City Osaka Japan 562-0012

Chapter 2 Components Identification

2.1 Accessories

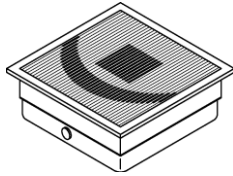

①

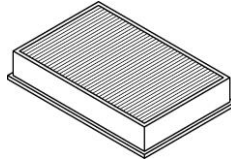

②

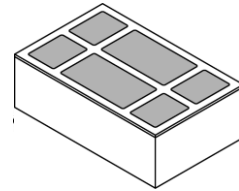

③

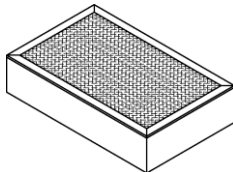

④

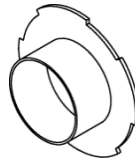

⑤

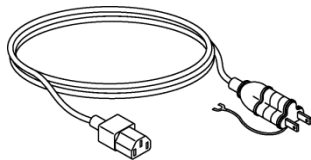

100V version

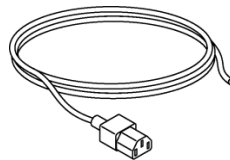

200V version (-T version)

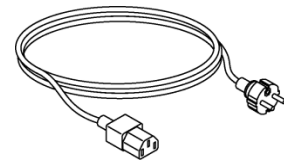

220-230V version (-CE version)

⑥



⑦

No.	Name	Function	Qty.	
①	Primary filter	Collects and adsorbs dust and fume.	1	
②	Secondary filter	Protects electrical parts from dust.	1	
③	Activated carbon cassette	Adsorbs odor.	1	
④	Exhaust HEPA filter	Cleans exhaust.	1	
⑤	Removable flange	Connects a suction duct / an exhaust duct.	2	
⑥	Power cable (3 m)	Connects to the power outlet. Shaped differently depending on power supply specifications.	100V version* ¹	1
			200 V version (-T version)	1
			220/230 V version (-CE version)	1
⑦	Instruction guide	Provides instructions for using the device.	1	

* 1 Can be used in the area of 100-115V.

2.2 Device Body

2.2.1 CBA-1000AT3-HC-DSA-V1

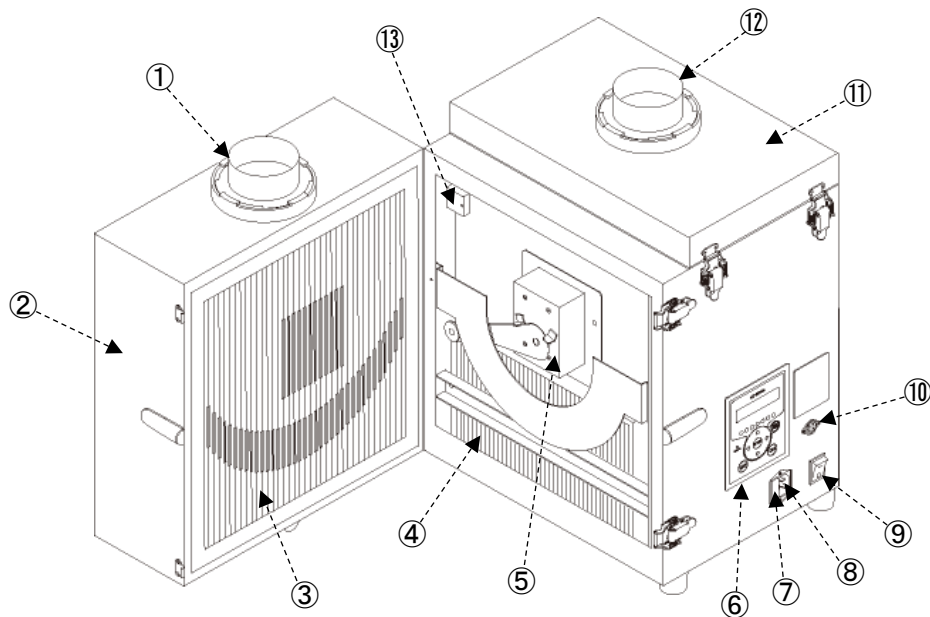

No.	Name	Function
①	Suction port (removable flange)	Connects a suction duct.
②	Suction side filter case	Contains primary filters.
③	Primary filter	Collects and adsorbs dust and fume.
④	Secondary filter	Protects electrical parts from dust.
⑤	Shaking motor chamber	Alleviates clogging in the primary filter.
⑥	AT3 panel (operation panel)	Operates the device.
⑦	Fuse box	Contains a fuse.
⑧	Power connector	Connects the power cable.
⑨	Main power switch	Turns on/off power to the device.
⑩	Remote connector	Connects a remote cable (optional).
⑪	Exhaust -side filter case	Contains Activated carbon cassette and Exhaust HEPA filter
⑫	Exhaust port (removable flange)	Connects an exhaust duct.
⑬	Battery cover	Contains a button battery

2.3 AT3 Panel

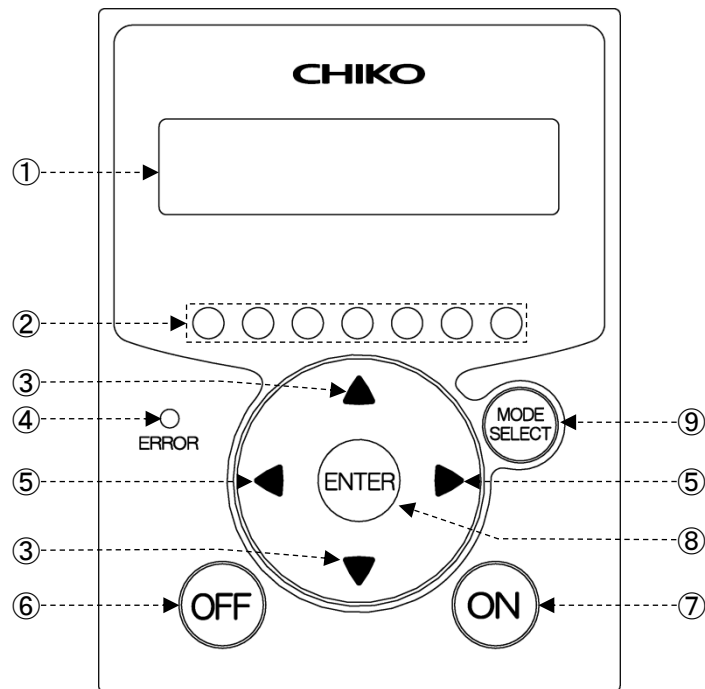

No.	Name	Function
①	Organic EL (OLED) display	Displays the operating status and various settings. Displays an error or warning number in case of an error or warning.
②	Suction power level lamps	Green lamps indicate a suction power level (1 to 7).
③	Up/Down arrow buttons	During stoppage or operation, switches among the content of the display. ☞ “2.4 Display Indications” (page 9) In MODE SELECT mode, cycles through parameters and changes numeric data. ☞ “Chapter 4 Configuring Settings (MODE SELECT Mode)” (page 15)
④	ERROR lamp	The red lamp lights upon detection of an error that stops device operation. The red lamp flickers upon detection of an error or warning that continues device operation.
⑤	Left/Right arrow buttons	During operation, each pressing of the Left (or Right) arrow button changes the suction power to the next lower (or higher) level. During MODE SELECT mode, each pressing of the Left (or Right) arrow button moves the cursor left (or right) to the next position.
⑥	OFF button	Stops the operation. During stoppage, holding this button down for three seconds clears the registered initial pressure. ☞ “3.3 Registering Initial Pressures” (page 14)
⑦	ON button	Starts operation.
⑧	ENTER button	During operation, holding this button down for three seconds causes transition to initial pressure registration. ☞ “3.3 Registering Initial Pressures” (page 14) During SELECT MODE mode, determines the selected parameter and its numeric data. ☞ “Chapter 4 Configuring Settings (MODE SELECT Mode)” (page 15)
⑨	MODE SELECT button	During stoppage, transits to the MODE SELECT mode. ☞ “Chapter 4 Configuring Settings (MODE SELECT Mode)” (page 15)

		During MODE SELECT mode, returns to the previous mode. During an error/warning, transits to the error history mode or error clear mode.
--	--	--

2.4 Display Indications

2.4.1 About Modes

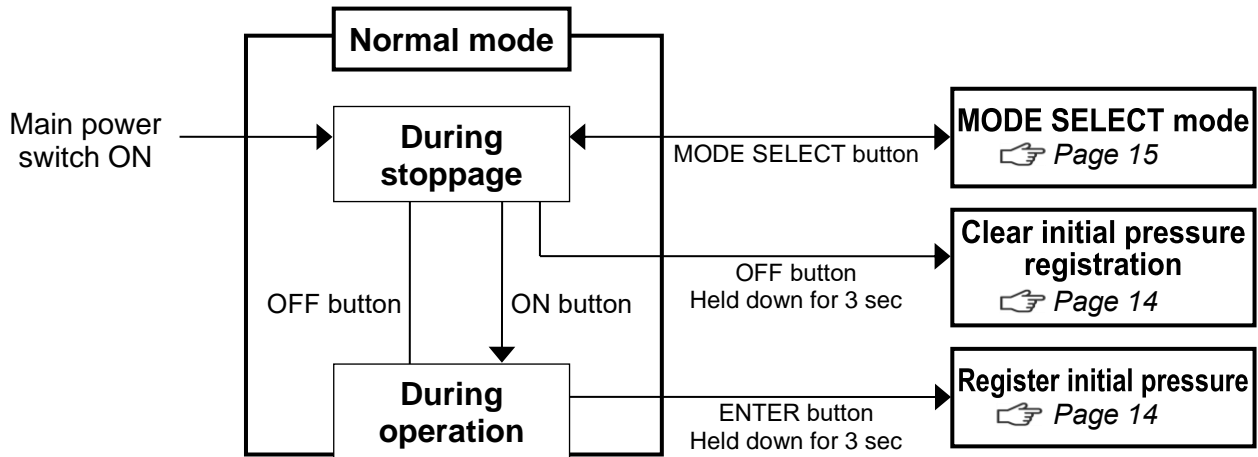

2.4.2 While Stopped

The Up/Down arrow buttons cycle through indications.

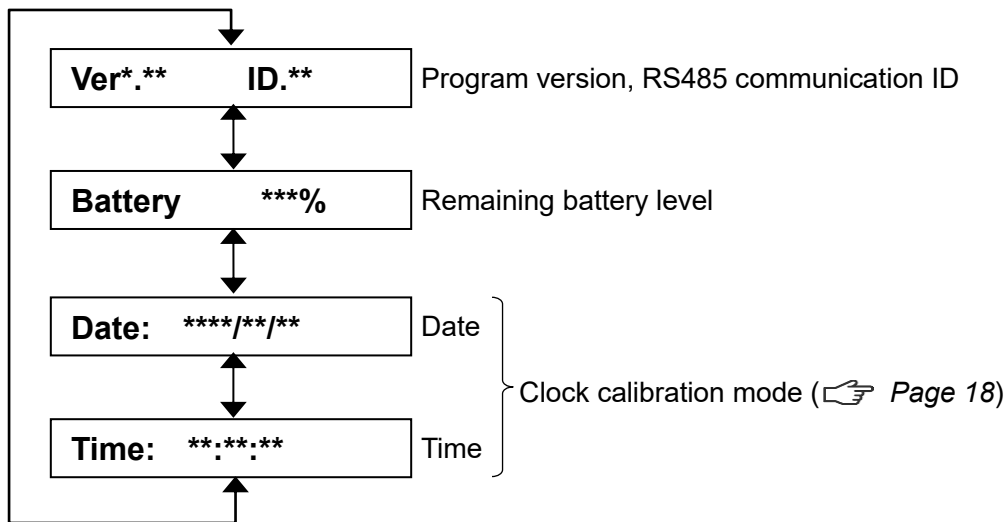

2.4.3 Indications During Operation

The Up/Down arrow buttons cycle through indications.

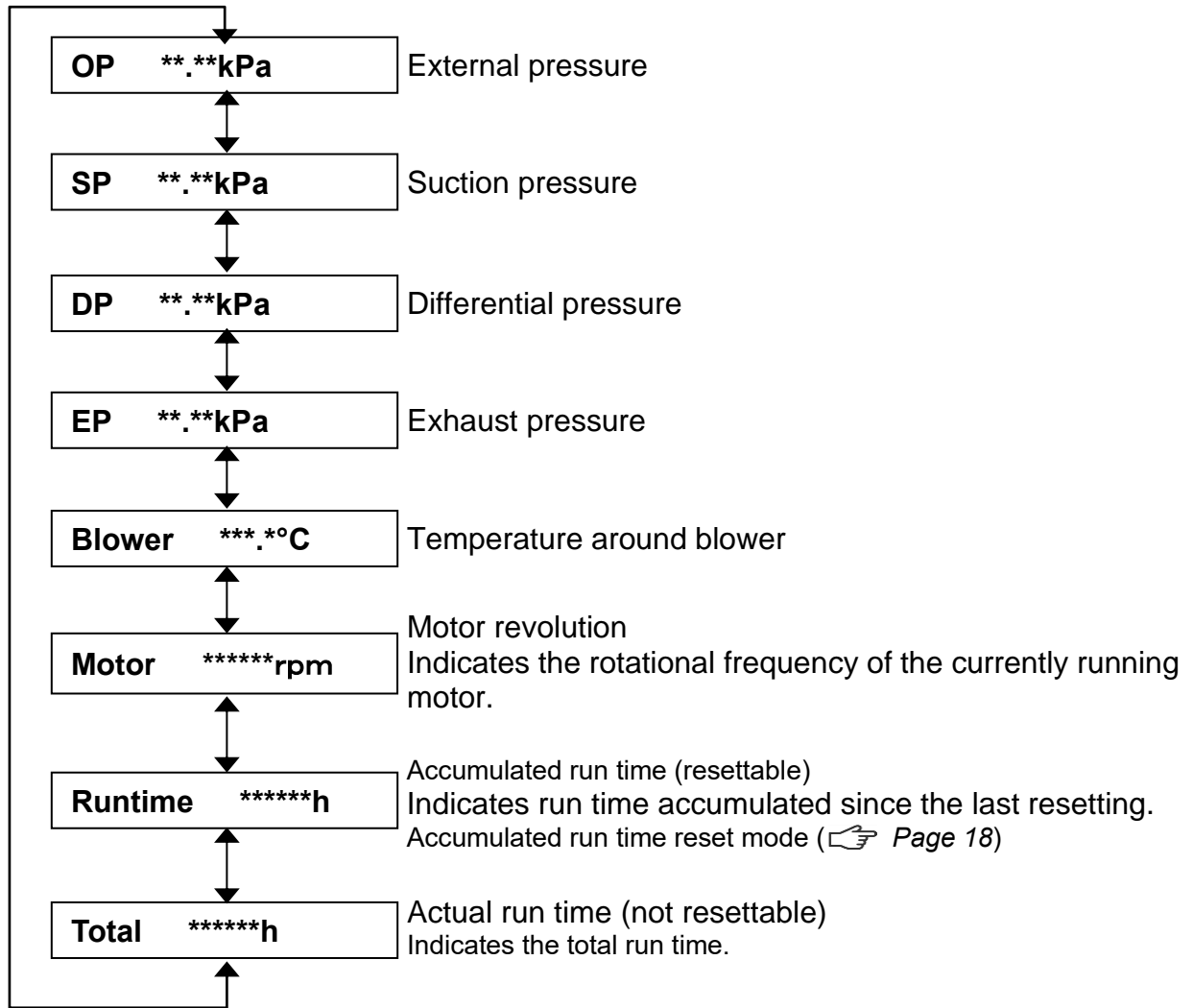

Chapter 3 Operation

3.1 Start-up Preparation

3.1.1 Installation

■ Installation location

To ensure operating safety and deliver the full performance of the device, install the device in a location that meets the following conditions:

Item	Description
Ambient temperature	0° to +40°C
Ambient humidity	80 RH% or lower (without dew condensation)
Ambient conditions	Indoors (not exposed to direct sunlight), free of corrosive/flammable gases, oil mist, and dust.

■ Be sure to peel off the sticker before use.

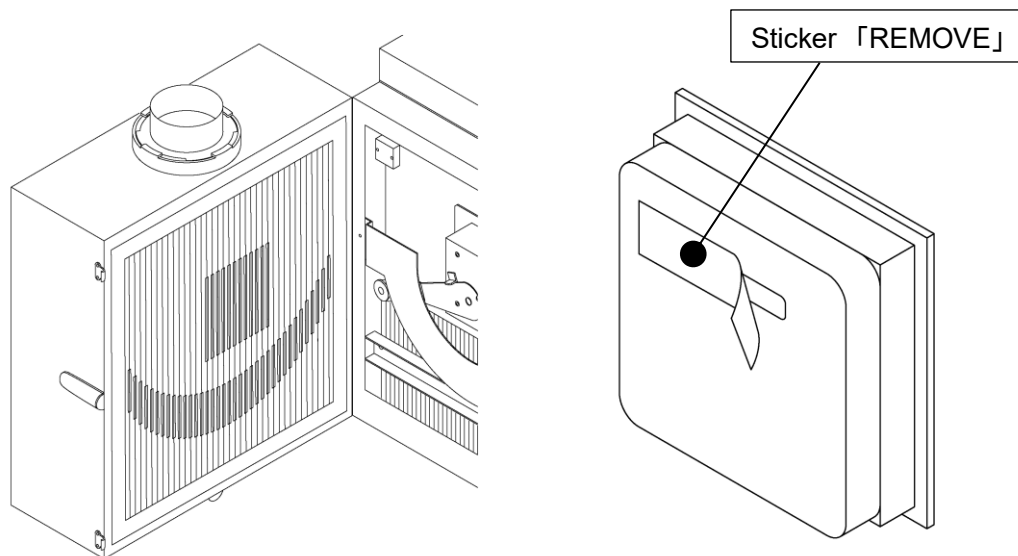

Before shipment, a sticker is attached to the primary filter to prevent zeolite from splashing from the filter during transport. Before using the device, take the primary filter out of the device body and peel off the sticker from the primary filter.

Chapter 3 Operation

■ Removing the button battery insulating sheet

While removing the insulation sheet from the button battery, turn on the electricity.

1. Before using the device, remove the insulation sheet from the button battery.
2. Release the two snap locks for suction-side filter case.
3. Open the suction-side filter case.

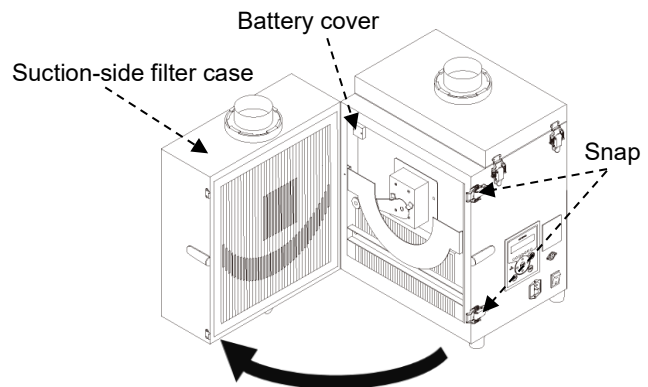

4. Pull the insulating sheet in the arrow direction (leftward or downward) off the battery cover.
The direction for pulling off the insulating sheet depends on the device model.

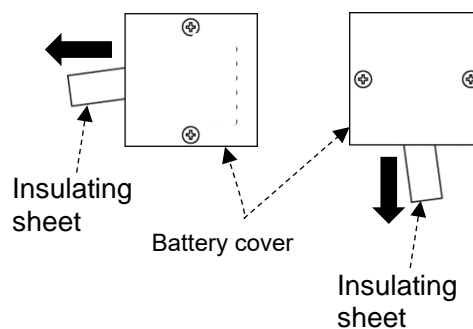

CAUTION







- It will cause a huge consumption of the battery, if the insulation sheet is removed while the device is turned off.

Note

- The button battery drains when the main power switch is OFF.
 $\leq 1 \mu\text{A}$ when main power is ON; 40 to 50 μA when main power is OFF
- The battery life (2 years, typical) depends on the usage. Take it as a guide value.

3.1.2 Wiring and Piping

■ Wiring

 WARNING	 <ul style="list-style-type: none"> Perform wiring firmly, without bending or pulling cables with excessive force. Fire or electric shock may result. Ensure that the power supply conforms to the specifications of the device.
	 <ul style="list-style-type: none"> Be sure to connect the ground wire.
 CAUTION	 <ul style="list-style-type: none"> Avoid multiple connections as they can cause voltage reduction. At reduced voltage, the device may fail to operate normally, resulting in failure.

The device is powered by a single-phase supply.
The tolerance of the supply voltage is $\pm 10\%$.

1. Connect the device attachment plug of the power cord to the power connector on the device.
2. Connect the power supply end of the power cord to the power outlet.

■ Piping

1. Turn the removable flange clockwise until it is secured on the suction port.
2. Connect the suction tube (to be prepared separately) to the removable flange.

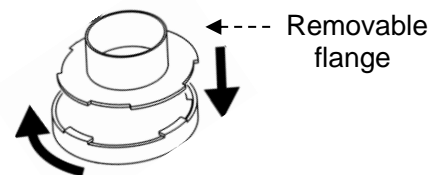

IMPORTANT

- Ensure appropriate piping during operation. The piping should be as short as practicable, with the piping port diameter not too small.

3.2 Operation

1. Turn on the main power switch.
The display indicates the program version and the ID for RS485 communication.
2. Press the ON button on the AT3 panel.
The device starts operation.
3. Check that abnormal noise is not generated and the suction is appropriate.
4. Set a desired suction power level by pressing the Left/Right arrow buttons.
The suction power is indicated by the suction power level lamps (1 to 7).

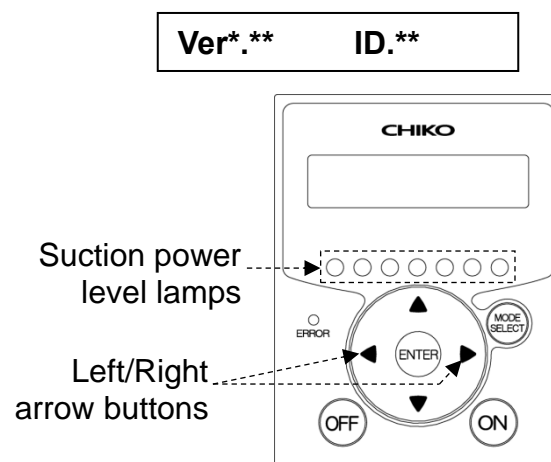

IMPORTANT

- Leave an interval of three minutes or more between on/off switching. Repeated on/off switching at intervals of less than three minutes, in particular less than 30 seconds, may cause failure.

3.3 Registering Initial Pressures

Air volume reduction due to filter clogging is judged based on a registered initial differential pressure and indicated as low air volume (WARN4). Register initial pressures through these steps:

1. Perform the wiring and piping of the device.
2. Start the device at a desired suction power level.
3. Press and hold down the ENTER button for three seconds.
The display shows “Initial DP Get Y”, prompting confirmation to register/update initial pressures.
4. To proceed with registration/update, press the ENTER button.
The device starts to acquire initial pressure.
If you do not want update, press the MODE SELECT button to return to normal operation.
5. The device runs through a sequence of suction power levels 1 to 7, to automatically acquire the differential pressure for each level.
While the device is acquiring initial pressures, the display alternates between the “Initial DP Check” message and the “suction power level and differential pressure” values.
6. When the registration completes, the display shows the “Initial DP Entry” message and the device returns to normal operation.

IMPORTANT

- Ensure that the filters are new.
- Update registered initial pressures once again if piping is changed or all filters are replaced (except for the exhaust filter) after registration of initial pressures.
- If initial pressures are not registered, an “initial pressure unregistered” warning (WARN6) appears.
- The registered initial pressures can be cleared by holding down the OFF button for three seconds when the device is in stop state.

● Clearing registered initial pressures

1. Hold down the OFF button for three seconds when the device is in stop state.
The display shows “Initial DP Clr Y”, prompting confirmation to clear registered initial pressures.
2. To clear them, press the ENTER button.
If you do not want to clear them, press the MODE SELECT button to return to normal operation.
3. When the clearing completes, the display shows the “Initial DP Clr” message and the device returns to the stop state.

Chapter 4 Configuring Settings (MODE SELECT Mode)

4.1 Screen Transitions in MODE SELECT Mode

To move to the MODE SELECT mode, press the MODE SELECT button during stoppage. The Up/Down arrow buttons cycle through parameters.

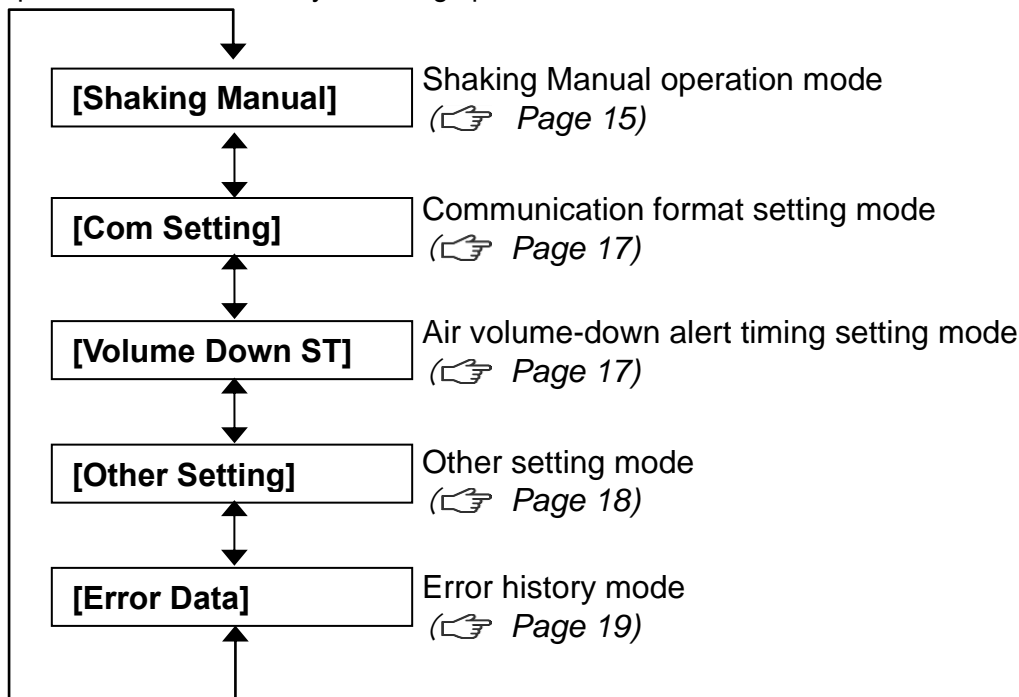

4.2 Shaking Setting mode

Set the following items

- Manual operation of shaking
☞ 「4.2.1 Shaking manual setting mode」(Page 15)
- Setting the shaking time
☞ 「4.2.2 Shaking time setting mode」(Page 16)
- Set the total time until the auto-shaking starts.
☞ 「4.2.3 Interval time setting mode for Auto shaking」(Page 16)

4.2.1 Shaking manual setting mode

Perform shaking while the device is in shutdown state.

1. Move to the MODE SELECT mode.
2. Press the Up/Down arrow buttons to move to the shaking manual operation mode.
3. Press the ENTER button.
The prompt “press enter key” appears.
4. After the ENTER button is pressed, the device performs shaking for 20 seconds.
5. To exit this mode, press the MODE SELECT button to return to normal mode.

Chapter 4 Configuring Settings

(MODE SELECT Mode)

4.2.2 Shaking time setting mode

The shaking operation time can be changed as desired.

(Setting range: 20~180sec Initial setting: 20sec)

1. Move to the MODE SELECT mode.
2. Press the Up/Down arrow buttons to move to the Shaking setting mode (“Shaking Set”).
3. Press the ENTER button.
4. Press the Up/Down arrow buttons to move to the Shaking time setting mode (“ShakeTime ***sec”).
5. Press the ENTER button.
6. Use the Right/left arrow buttons to change the digit, and the Up/Down arrow buttons to change the value.
7. Press the ENTER button to determine the value.
8. To exit this mode, press the MODE SELECT button to return to normal mode.

4.2.3 Interval time setting mode for Auto shaking

The shaking operation time can be changed as desired.

(Setting range: 0~60min Initial setting: 60min)

1. Move to the MODE SELECT mode.
2. Press the Up/Down arrow buttons to move to the Shaking setting mode (“Shaking Set”).
3. Press the ENTER button.
4. Press the Up/Down arrow buttons to move to the Interval time setting mode for Auto shaking (“Interval ***min”).
5. Press the ENTER button.
6. Use the Right/left arrow buttons to change the digit, and the Up/Down arrow buttons to change the value.
7. Press the ENTER button to determine the value.
8. To exit this mode, press the MODE SELECT button to return to normal mode.

4.3 Communication Format Setting Mode (When Equipped with Communication Function)

This mode sets the below listed items of serial communication format.
The settings are enabled after the main power switch is turned off and back on.

Item	Setting	Default
Communication station number	1 to 25	1
Baud rate	9600 bps, 19200 bps, 38400 bps, 57600 bps, 115200 bps	9600 bps
Bit length and parity	Bit length = 8 bits, with no parity Bit length = 8 bits, odd parity Bit length = 8 bits, even parity Bit length = 9 bits, with no parity	Bit length = 8 bits, with no parity
Stop bit	Stop bit = 1 bit Stop bit = 2 bits	Stop bit = 1 bit

1. Move to the MODE SELECT mode.
2. Press the Up/Down arrow buttons to move to the communication format setting mode ("Com Setting").
3. Press the ENTER button.
The communication station number check screen appears, showing the current settings.
4. Press the Up/Down arrow buttons to move to the item you want to set.
5. Press the ENTER button.
The setting screen appears.
6. Press the Up/Down arrow buttons to select the desired setting.
7. Press the ENTER button to determine the setting.
8. To exit this mode, press the MODE SELECT button to return to normal mode.

4.4 Air Volume-Down Alert Timing Setting Mode

This mode allows for changing the timing for displaying an air volume-down warning (WARN4) as desired.

1. Move to the MODE SELECT mode.
2. Press the Up/Down arrow buttons to move to the air volume-down alert timing setting mode ("Volume Down ST").
3. Press the ENTER button.
The current setting appears.
The default is 50%, displayed as "3: Down to 50%".
4. Press the Up/Down arrow buttons to select a timing between 30 to 70%.
A lower setting causes the air volume-down alert to occur later, and vice versa.

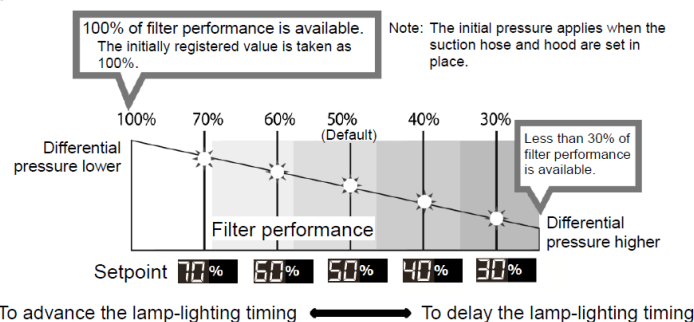

5. Press the ENTER button to determine the setting.
6. To exit this mode, press the MODE SELECT button to return to normal mode.

4.5 Other Setting Mode

The parameters listed below can be set.

- Date/time setting
 ☞ “4.5.1 Clock Calibration Mode” (page 18)
- Accumulated run time resetting
 ☞ “4.5.2 Accumulated Run Time Reset Mode” (page 18)
- Setpoint resetting
 ☞ “4.5.3 Setpoint Reset Mode” (page 19)

4.5.1 Clock Calibration Mode

This mode sets date and time.

1. Move to the MODE SELECT mode.
2. Press the Up/Down arrow buttons to move to the other setting mode (“Other Setting”).
3. Press the ENTER button.
 The screen displays “Time Adjust”.
4. Press the ENTER button.
 The date setting screen appears.
5. Press the Up/Down arrow buttons to change the value.
6. Press the ENTER button to determine the value.
 Set the value in this order: year, month, and day.
7. After the date is set, the time setting screen appears.
8. Press the Up/Down arrow buttons to change the value.
9. Press the ENTER button to determine the value.
 Set the value in this order: hours, minutes, and seconds.
10. To exit this mode, press the MODE SELECT button to return to normal mode.

4.5.2 Accumulated Run Time Reset Mode

This mode resets the accumulated run time (“Runtime”).

1. Move to the MODE SELECT mode.
2. Press the Up/Down arrow buttons to move to the other setting mode (“Other Setting”).
3. Press the ENTER button.
 The screen displays “Time Adjust”.
4. Press the Up/Down arrow buttons to change the display to “[Runtime Reset]”.
5. Press the ENTER button.
 The display shows “Reset Runtime Y”, prompting confirmation to reset the accumulated run time.
 To reset, press the ENTER button.
6. To exit this mode, press the MODE SELECT button to return to normal mode.

4.5.3 Setpoint Reset Mode

This mode allows for restoring the defaults for communication format, air volume-down alert timing, and resetting the accumulated run time.

1. Move to the MODE SELECT mode.
2. Press the Up/Down arrow buttons to move to the other setting mode (“Other Setting”).
3. Press the ENTER button.
The screen displays “Time Adjust”.
4. Press the Up/Down arrow buttons to change the display to “[Setting Reset]”.
5. Press the ENTER button.
The display shows “1:YES”, prompting confirmation to reset setpoints.
To reset, press the ENTER button.
6. The display shows “1:START” for reconfirmation.
7. Press the ENTER button to reset the setpoints and move the device to normal mode.

4.6 Error History Mode

The error history allows for checking four occurrences of errors.
The error history is cleared by turning off the main power switch.

1. Move to the MODE SELECT mode.
2. Press the Up/Down arrow buttons to move to the error history mode (“Error Data”).
3. Press the ENTER button.
The display indicates the number of the most recent error that has occurred and the accumulated run time at that occurrence.
4. Press the Down arrow button to display the history of four errors in order from the latest.
5. To exit this mode, press the MODE SELECT button to return to normal mode.

Chapter 5 Maintenance and Checkup



- Before starting maintenance and checkup, be sure to break the electrical circuit by turning off the power supply and disconnecting the plug from the power outlet.

5.1 Replacing Filters

If clogging occurs, a “WARN2” warning appears. Replace the primary filter.

5.1.1 Replacing the Primary Filter

IMPORTANT

- The primary filter should be replaced in an area large enough to open the suction-side filter case.

1. Release the two snap locks for suction-side filter case.
2. Open the suction-side filter case and remove the primary filter.

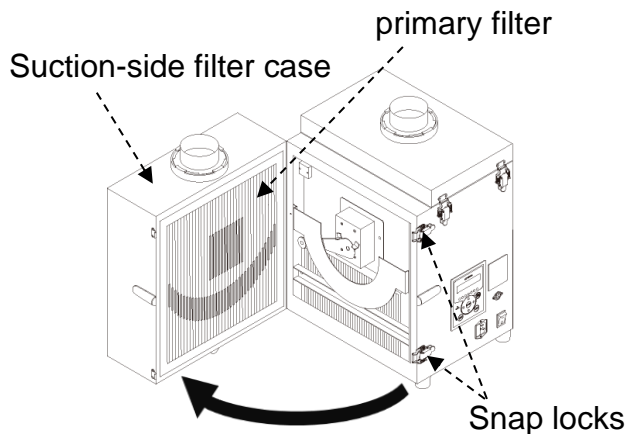

3. Install a new primary filter.
4. Close the suction-side filter case and secure it with the two snap locks.

5.1.2 Replacing Secondary Filter

IMPORTANT

- The secondary filter should be replaced in an area large enough to open the suction-side filter case.

1. Release the two snap locks for suction-side filter case.
2. If the shaking arm is stopped at the center, move it to either side before removing the guard, etc.
3. Remove the two screws flanking the shaking guard and remove the guard.
4. Remove the two screws flanking the filter presser plate and remove the plate.
5. Remove the secondary filter.

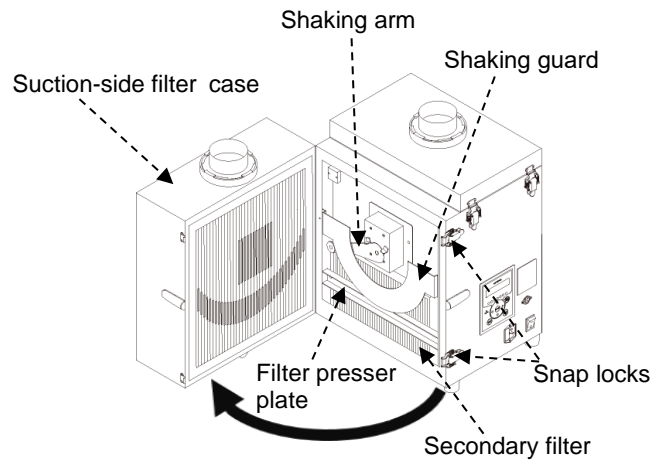

6. Install a new secondary filter.
7. Install the filter presser plate (removed in step 4) and the shaking guard (removed in step 3) using screws, close the suction-side filter case, and secure the case with the two snap locks.

5.1.3 Replacing the Exhaust Filter

CAUTION



- Avoid installing the filter inside out.

IMPORTANT

- The exhaust filter should be replaced in an area with a large free space.

1. Remove the exhaust filter chamber by releasing its four snap locks each on the left and right sides.
2. Remove the HEPA filter.

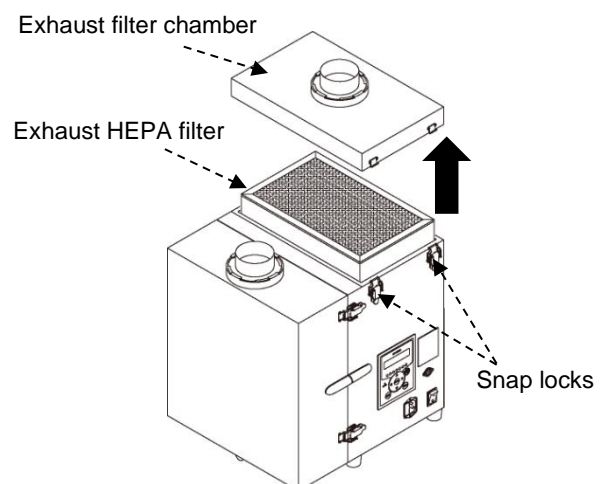

Chapter 5 Maintenance and Checkup

3. Lift the activated carbon drawer and remove the activated carbon cassette.
4. Install a new activated carbon cassette.
5. Install a new exhaust filter.
6. Install the exhaust filter chamber back in place.

Note: Replace the activated carbon cassette if the exhaust odor smells.

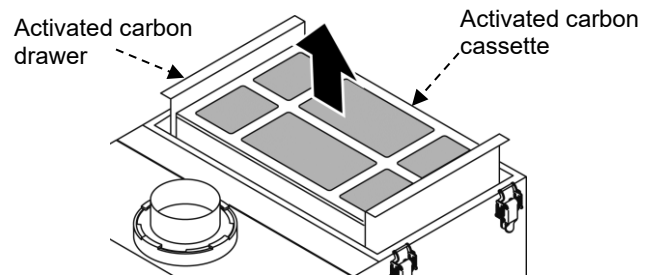

5.2 Replacing Fuse

Replace one fuses if any of them is blown by an overcurrent due to trouble with internal equipment. The fuses are contained in the black box beside the power switch. The replacing fuses should be those designated by CHIKO AIRTEC.

Designated fuses: 218 Series from Littell fuse [250V 10A]

1. Take out the black box beside the power switch. If it cannot be taken out smoothly, please use a flathead screwdriver or other thin-tipped tool to take it out carefully.
2. Remove the fuses out of the fuse box and replace with new ones.

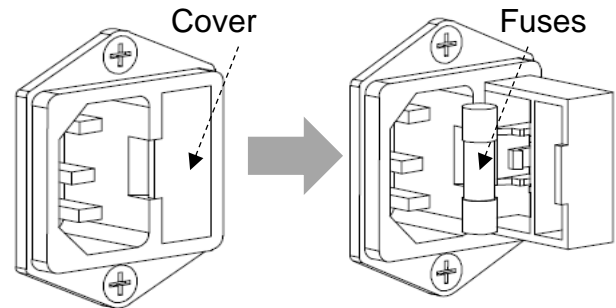

5.3 Replacing the Button Battery

CAUTION



- The button battery case used in the device is for CR2477 size. Do not use button batteries other than CR2477.
- Turn on the electricity of the device while replacing the battery, or it will cause a huge consumption of the battery.

1. Turn on the electricity of the device.
2. Open the suction-side filter case.
3. Remove the battery cover by extracting its two screws.

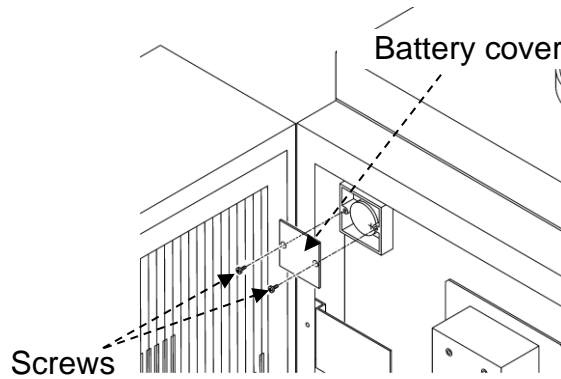

4. Push the claw rightward and remove the button battery.
5. Replace with a new button battery.
6. Install the battery cover back in place.
7. Cut off the electricity of the device.

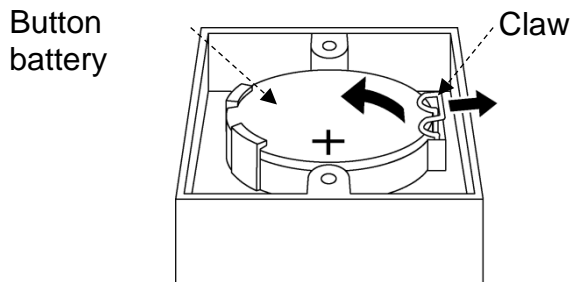

5.4 Daily Inspection

Inspection item	Frequency	Description
Filter case	Before operation	Is the case closed completely?
Suction port	Before operation	Is the suction port closed?
Exhaust status	Once/day	Is the exhaust port closed?
Operation panel status	Once/day	Are errors or warnings displayed?

5.5 Errors/Warnings

If an error/warning occurs, the self-diagnosis function built-in the device lights (flashes) the ERROR lamp and shows display data and error number alternately on the display.

For a description of errors/warnings displayed, see “5.5.2 Error / Warning Table (page 25).

For faults and conditions not covered by self-diagnosis, see “5.6 Troubleshooting” (page 26).

5.5.1 Action on Errors/Warnings

If the self-diagnosis function of this device has detected an error or warning, take the steps below to clear the error or warning.

The screenshots for illustration are provided as examples.

1. If an error/warning occurs, the ERROR lamp lights (flashes) and the display shows display data and error number alternately. If there are two or more error/warning occurrences, the one with the highest priority is displayed.



2. Press the MODE SELECT button to move to the error history mode. If there are two or more error/warning occurrences, the number of occurrences precedes the error number.

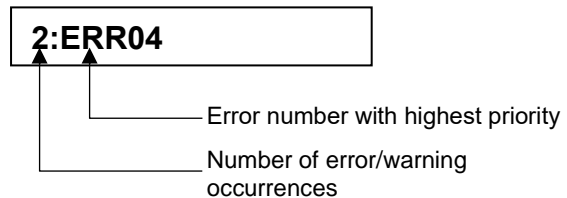

3. If there are two or more error/warning occurrences, press the Up/Down arrow buttons to check the error numbers.

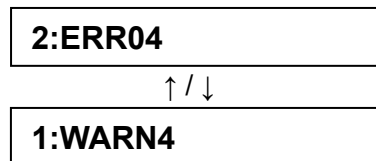

4. Take an action appropriate for the error number shown on the display.
 ➔ “5.5.2 Error / Warning Table” (page 25)
5. Press the MODE SELECT button to move to the error clear mode.



6. To clear the error/warning, press the ENTER button to return to normal mode. To leave the error/warning uncleared, press the MODE SELECT button to return to normal mode.

If an error/warning is left uncleared:

- For an error/warning that continues the operation....All buttons remain enabled.
- For an error/warning that stops the operation.....The ON button is disabled.
 To resume the operation, clear the error/warning.

IMPORTANT	<ul style="list-style-type: none"> • Once WARN6 and WARN7 cancel warning, they will not perform an alarm display until they return on a master electrical switch next.
------------------	---

5.5.2 Error / Warning Table

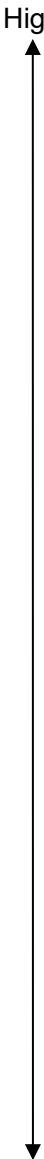
Priority	Error No.	Error/warning	Description	ERROR lamp	Device operation	Action
High  Low	ERR03	Rotational frequency error	Motor rotational frequency declining (or stopping)	Flashing	Remains operational	Follow the remedies for ② in “5.6 Troubleshooting” (👉 Page 26).
	ERR04	Internal temperature error	Temperature around the blower is too high.	Lit	Stop	Follow the remedies for ② in “5.6 Troubleshooting” (👉 Page 26).
	ERR06	Pressure error	Operation continued at low pressure for more than preset period.	Lit	Stop	Follow the remedies for ② in “5.6 Troubleshooting” (👉 Page 26).
	ERR07	F-RAM write error	Cannot write to F-RAM.	Flashing	Remains operational	Contact CHIKO AIRTEC.
	ERR08	Communication error	BCC judgment mismatch	Flashing	Remains operational	Contact CHIKO AIRTEC.
	WARN1	Internal temperature high	Temperature around the blower is close to the error threshold.	Flashing	Remains operational	Follow the remedies for ② in “5.6 Troubleshooting” (👉 Page 26).
	WARN2	Filter replacement time limit expired	Operation continued at low air volume for more than preset period.	Flashing	Remains operational	Follow the remedies for ③ in “5.6 Troubleshooting” (👉 Page 26).
	WARN3	Inadequate pressure (suction)	Suction pressure is low.	Flashing	Remains operational	Follow the remedies for ② in “5.6 Troubleshooting” (👉 Page 26).
	WARN4	Inadequate air volume	Air volume is reduced by filter clogging.	Flashing	Remains operational	Follow the remedies for ③ in “5.6 Troubleshooting” (👉 Page 26).
	WARN5	Exhaust pressure error	Exhaust pressure is too high.	Flashing	Remains operational	Follow the remedies for ③ or ④ in “5.6 Troubleshooting” (👉 Page 26).
	WARN6	Initial pressure unregistered	Initial pressure is not registered yet.	Flashing	Remains operational	Register initial pressures. (👉 Page 14)
	WARN7	Battery voltage low	Remaining battery level is low.	Flashing	Remains operational	Replace the button battery. (👉 Page 23)

5.6 Troubleshooting

No.	Trouble phenomenon	Cause	Remedy
①	Organic EL display shows nothing.	Power not turned on	Turn on the power
		Blown fuse	Replace the fuses. ☞ "5.2 Replacing Fuse" (page 22)
②	Motor fails to start or suddenly stops running.	Faulty motor	Call for repair. The motor must be replaced.
		Stopped due to overload or abnormal temperature	[1] Check that the exhaust/suction ports are not blocked. [2] Check the rated voltage. [3] Check for multiple (octopus) connections. [4] Check for motor overheat due to either filter clogging or suction temperature. After the checks [1] to [4], take corrective action, and then turn the main power switch off and back on. If the operation cannot resume, the temperature thermostat of the motor may be active. Turn off the main power, and after 30 minutes, resume the operation.
		Primary or secondary filter not in place	Install the primary and secondary filters correctly.
		Snap locks disengaged	Engage all the snap locks firmly.
③	Lower suction force	Clogged filter	Replace filters. ☞ "5.1 Replacing Filters" (page 20) If filters are left clogged, the device may result in "untrapped particles" or "temperature rise in dust collector".
		Clogged piping or suction port	Check if piping is clogged or the suction port blocked.
		Faulty motor	Call for repair. The motor must be replaced.
④	Untrapped particles	Improper filter installation	Reinstall filters. ☞ "5.1 Replacing Filters" (page 20)
		Filter broken or past service life	Replace filters. ☞ "5.1 Replacing Filters" (page 20)
		Clogged filter	Replace filters. ☞ "5.1 Replacing Filters" (page20)
⑤	Odd noise or vibration from motor	Foreign matter entered in blower	Call for repair.
		Broken motor bearing	Call for repair.

Note: For other phenomena, contact CHIKO AIRTEC.

Chapter 6 Useful Utilization (Optional)

6.1 Remote Cable

6.1.1 Electrical Diagram

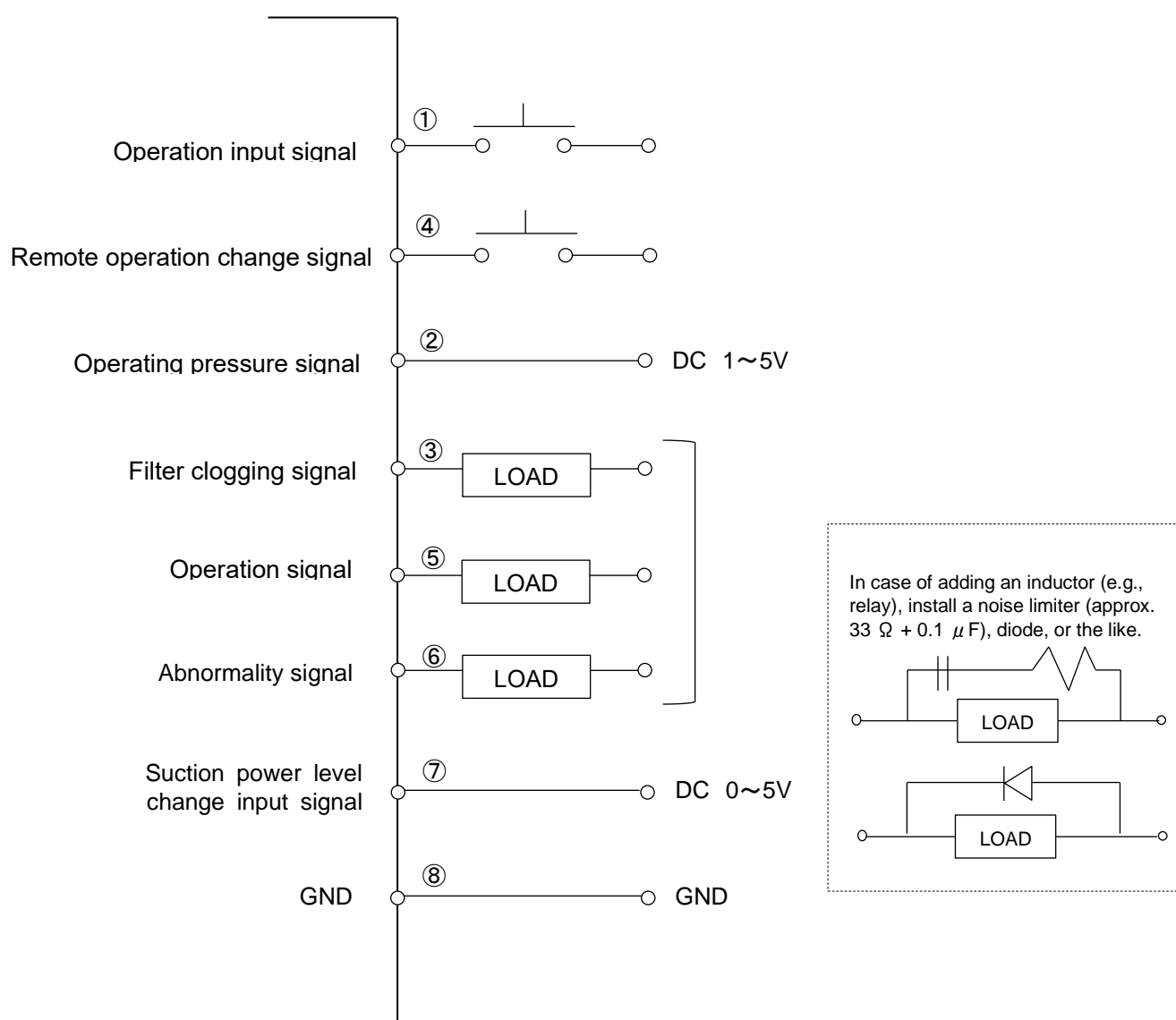

■ Remote Operation

Pin ④.....When turned on, control switches to the remote mode, enabling remote operation while disabling ordinary operation via the AT3 panel.

Pin ②.....Outputs an analog pressure signal.

Pins ③, ⑤, and ⑥...In case of adding an inductor (e.g., relay), install a noise limiter (approx. 33 Ω + 0.1 μF), diode, or the like.

■ Connection Example

● Pins ① and ④ (input)

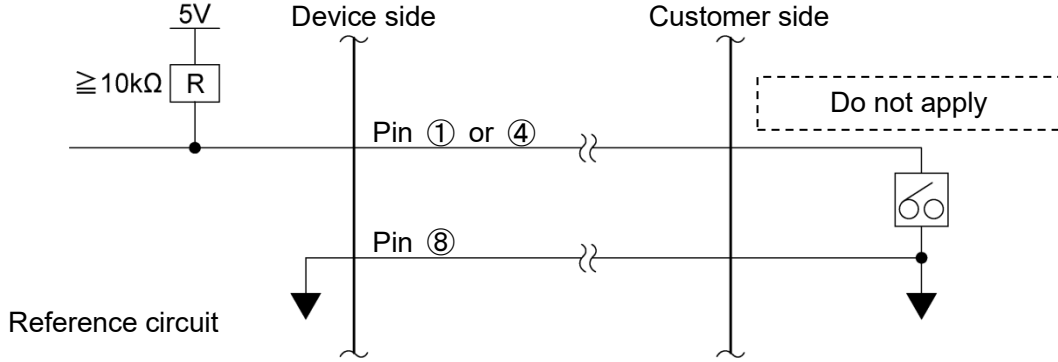

● ② pin (analog output)

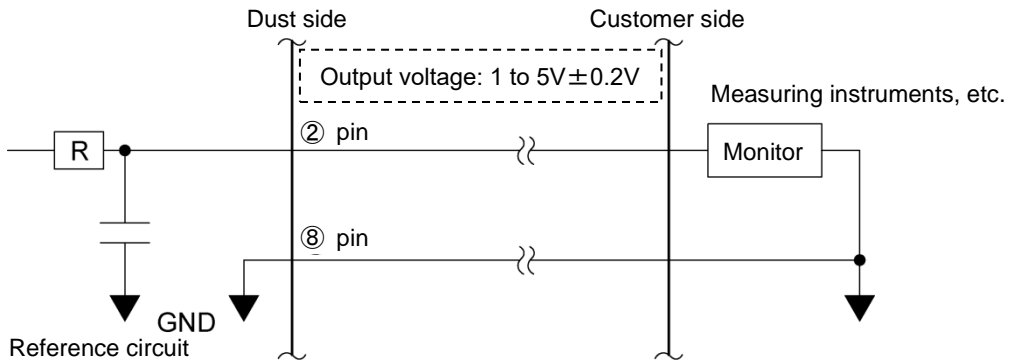

● Pins ③, ⑤, and ⑥ (open collector output)

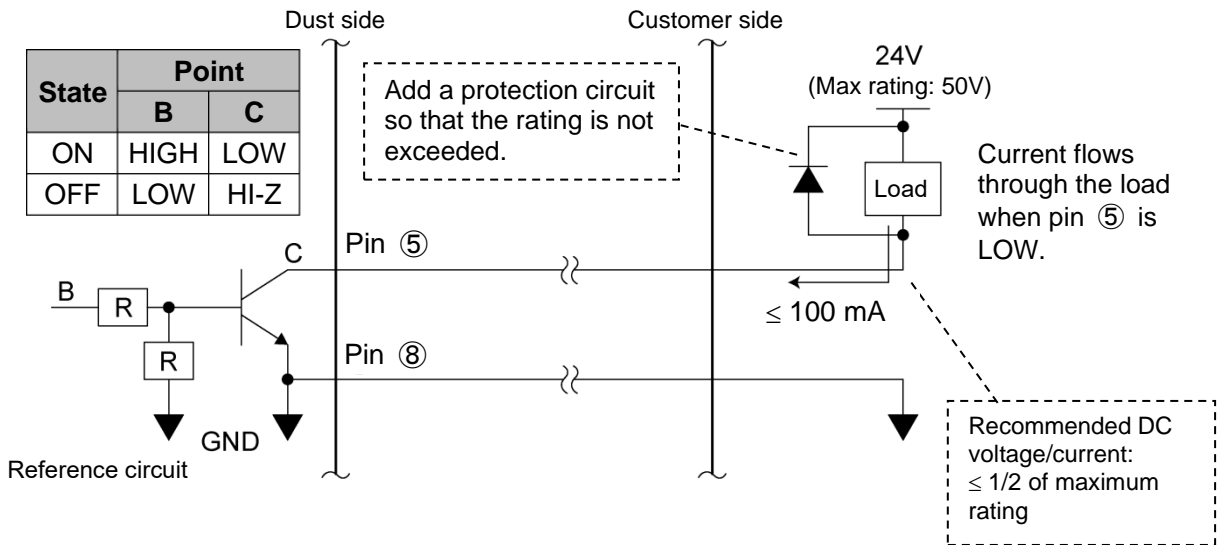

● Pin ⑦ (input)

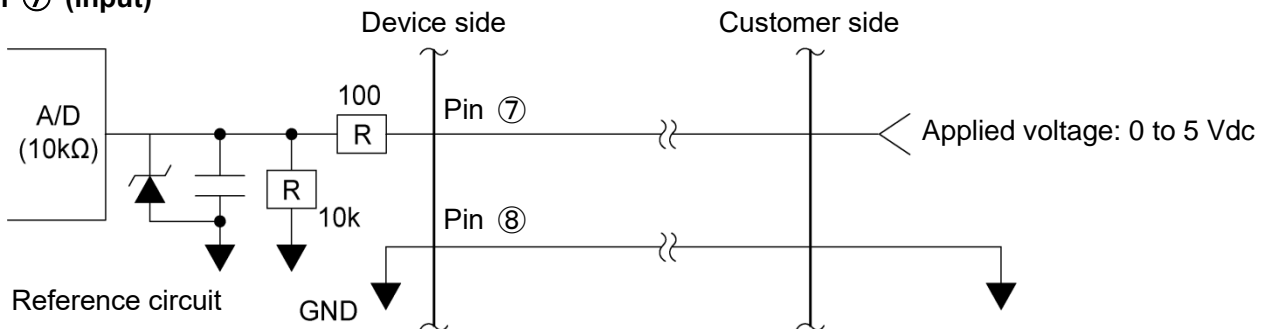

6.1.2 Pin Assignments

Wire color	Pin #	Signal name	Description	
Black	①	Operation input signal ^{*1}	Remote signals (Input)	With ④ and ⑧ short-circuited, ① is short-circuited to start operation.
Red/white	④	Remote operation change signal ^{*1}		④ and ⑧ are short-circuited to start remote operation. Once this short circuit is established, ordinary operation via the touch panel is disabled.
Yellow	⑦	Suction power level change ^{*2}		Voltage (0 to 5 V) can be applied between ⑦ and ⑧ to change suction power levels.
Yellow/white	⑧	GND		—
Black/white	②	Operating pressure signal	Output signals	Outputs the current operating pressure. Analog signal: 1 to 5 V; impedance $\geq 4.7 \text{ k}\Omega$
Red	③	Filter clogging output signal ^{*3}		Outputs a clogging signal. Open collector output: NPN
Green	⑤	Operation output signal ^{*3}		Outputs an operation signal (ON lamp). Open collector output: NPN
Green/white	⑥	Abnormality signal detection ^{*3}		Anomalous signal Detection Open collector output: NPN

【Filter clogging signal】 : When WARN2, WARN4 or WARN5 occurred

【Abnormality signal】 : When any ERR occurred

*1 Contact input (non-voltage contact)

*2: Analog input (0 to 5 V)

Do not apply more than +5.0 V.

Threshold table for voltage applied to pin ⑦

Suction power level	Voltage (Vdc)
1	0.6 to 1.1
2	1.2 to 1.7
3	1.8 to 2.3
4	2.4 to 2.9
5	3.0 to 3.5
6	3.6 to 4.1
7	4.2 to 5.0

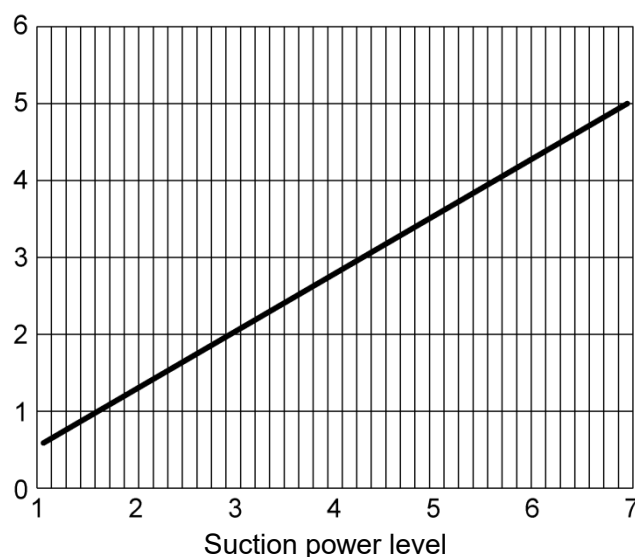

Allow for an error of $\pm 4\%$ when setting voltage. Specifically, apply the midpoint of the voltage range for each level.

*3: Open collector output

The maximum absolute rating is 50 V for voltage and 100 mA for current.

The recommended value is half or less of the rating.

6.1.3 Remote Operation

- For on/off switching via remote operation, short-circuit pins ④ and ⑧.
Pin ① is short-circuited → ON
Pin ① is not short-circuited → OFF
☞ 6.1.2 Pin Assignments (page 29)
- Do not short-circuit between pins ④ and ⑧ when taking signals by on/off switching on the device side.
Take out desired output signals as per the description in 6.1.2 Pin Assignments (page 29)".
- Initial pressure registration, ON/OFF operation and suction power levels cannot be operated or changed on the device side during transition to remote operation.
- The current suction power level is stored in memory. This means that the previously effective level is stored even if main power is turned off.

6.2 Communication Function

With the optional communication board set (Model: RS-485 or RS-EN), it is possible to retrieve the information like the ON/OFF operation and filter clogging status.

6.2.1 RS485 Communication

Communication Format Setting Mode (When Equipped with Communication Function)" for instructions on configuring communication settings.

☞ 4.3 Communication Format Setting Mode (When Equipped with Communication Function) (page 17)

6.2.2 Ethernet

For details, refer to the instruction manual of the Ethernet device you purchased separately.

6.3 Removable Flange

Flanges can be replaced without using tools if a different diameter of suction port is required to suit particular operating environments

Replaceable flange diameters

Model	Flange diameter (mm)			
	φ 38	φ 50	φ 65	φ 75
CBA-1000AT3	FRJ-D-38-35-108	FRJ-D-50-35-108	FRJ-D-65-35-108	FRJ-D-75-35-108

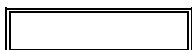

: The removable flanges shown enclosed in double lines are included in standard shipment.

Chapter 7 Appendix

7.1 Specifications

Model	Motor rated output	Voltage	Current value	Frequency	Max. suction volume*2	Max. suction static pressure	Noise value*1	Mass
CBA-1000AT3-HC-DSA-V1	500 W	100V*3 single phase	7.8A	50/60 Hz	3.2m ³ /min	9.3-9.5kPa	54-59dB	32.5kg
CBA-1000AT3-HC-DSA-V1-T		200 V single phase	4.9A					
CBA-1000AT3-HC-DSA-V1-CE		220 to 230 V single phase	4.5A					

*1: Noise value is measured with a hose connected to the suction port, at a distance of 1 m from the device, on the A scale dB.

*2 2.7-2.9 m³/min When zeolite is adhered to the filter.

*3 Can be used in the area of 100-115V.

7.2 Consumables List

Filter	Replacement intervals	Type
Primary filter	3 to 6 months	HDF-3535-120-ZEO
Secondary filter		CHF-2030-50
Exhaust HEPA filter	6 to 12 months	HEP-3220-69
Activated carbon cassette		ACC-3220-100

*1: The replacement intervals vary with the use frequency, shaking frequency, environment, and suction concentration (substance and composition) at the customer's site.

7.3 Electrical Diagram

7.3.1 CBA-1000AT3-DSA-HC-V1

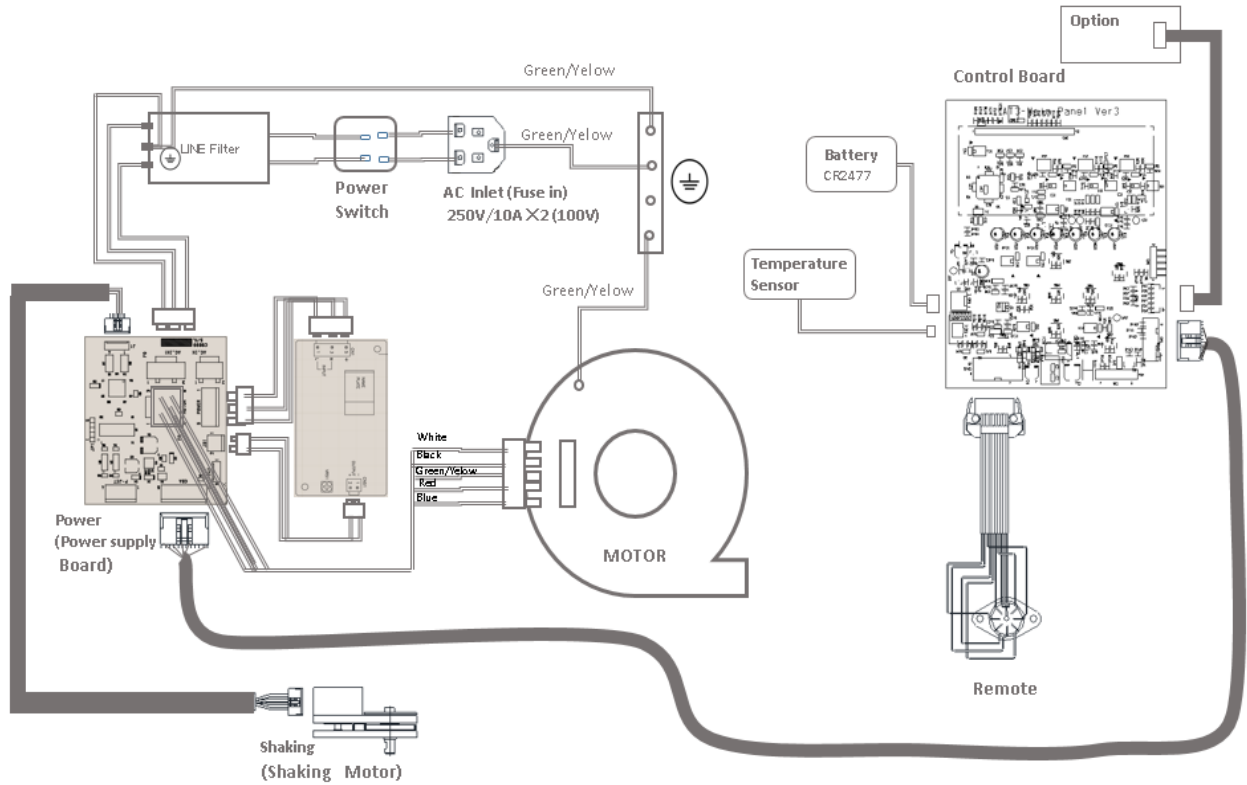

For illustration purpose, these boards are viewed with the opposite sides seen through.

Scope of Warranty and Responsibility

● Warranty period

We will repair free of charge any failures or damages that may occur during normal operating conditions within 12 months of shipment.

However, this does not apply to the consumables listed in "7.2 Consumables List".

☞ "7.2 Consumables List" (page 31)

The following cases will be handled as a charged service even within the warranty period.

- Failure or damage caused by violation of the instructions in this document.
- Failure or damage due to use in an operating environment other than that described in this document.
- Repair, alteration, disassembly, or similar action done any party other than CHIKO AIRTEC or a CHIKO AIRTEC-designated sales agent.
- Blemish, contamination, or other appearance change that may occur during use.
- Replacement of any consumable or accessory, or use of any part not designated by CHIKO AIRTEC.
- Failure of damage due to falling after purchase or accident during transport.
- Failure or damage due to natural disasters, such as: fire, salt damage, gaseous damage, earthquake, wind and flood damage, lightning strike, and abnormal voltage.

● Repairs

Travel expenses for on-site service will be chargeable whether within or outside the warranty period.

For repair reasons, improved parts may be used for repair.

CHIKO AIRTEC will not be liable for any damage resulting from use of this device, such as damage caused by failure of the device or by erasure of data.

■ Memo about purchase

Model		Serial No.
Date of purchase		Operation start date:
Your name		
Address	Phone Person in charge	

販売元/Distributor



※支店・営業所・製造拠点の最新情報は、弊社ホームページよりご確認下さい。
For the latest information on our branches, sales offices, and factories, please visit our website.
<https://www.showadenki.co.jp>

製造元/Manufacturer

チコーエアーテック株式会社
CHIKO AIRTEC CO.,LTD.
〒562-0012 大阪府箕面市白島 2-27-24
2-27-24,Hakushima, Minoh, Osaka 562-0012, Japan
TEL (81) 072-720-5151 FAX (81) 072-720-5133
URL <http://chiko-airtec.jp/>