

Operation Manual for

Dustrésa

the Compact Dust Collector

CFA-110
CFA-H215C
CFA-H215T
CFA-H220
CFA-H240



Introduction

Thank you for choosing our Dustrésa dust collector in the CFA series from among so many similar products on the market.

Showa Denki, as a dedicated manufacturer of blowers and dust collectors, has supplied innovative products developed by making the best use of its flow and rotary machine expertise. Compact, yet featuring high performance and low energy consumption, your Dustrésa will serve you for long safe and sound as long as you follow the instructions in this manual.



It is recommended that you keep the manual on hand for quick reference.

This manual contains all necessary information from installation to operation about the following varieties of Dustrésa:

CFA-110	100 V, 50 & 60 Hz commonly used
CFA-H215C	100 V, 50 or 60 Hz exclusively used
CFA-H215T	200 V, 50 or 60 Hz exclusively used
CFA-H220	200 V, 50 or 60 Hz exclusively used
CFA-H240	200 V, 50 or 60 Hz exclusively used

Symbols used herein

The symbols and headwords found in this manual respectively have the following meaning:

 Warning	If failed to observe the relevant instructions, it could cause death or serious injury.
 Caution	If failed to observe the relevant instructions, it could cause injury or property damage.



indicates what must not be done.



indicates what requires the use of good care.



indicates what must be done.

Contents

Page

Chapter 1	Cautions for safety	- 1 -
Chapter 2	Outline of the dust collector	- 3 -
	Configuration	- 3 -
	Components	- 3 -
Chapter 3	Installation	- 5 -
	Installation	- 6 -
	Electrical wiring	- 6 -
	Hood and connection of the duct	- 7 -
	Trial operation	- 7 -
Chapter 4	Operation	- 7 -
	Routine operation	- 7 -
	How shake off the dust	- 8 -
	Caution	- 8 -
Chapter 5	Maintenance	- 9 -
	What and when to inspect	- 9 -
	Replacing the filter cloth	- 10 -
	Adjusting tension of the shaking rope	- 11 -
	Replacement filter cloth sizes	- 12 -
	Troubleshooting	- 13 -
	Specifications	- 14 -
	Outside dimensions	- 14 -
Chapter 6	Warranty	- 16 -

Warning



Any Dustrésa must not suck the following things:

- **A lit cigarette or match, hot dust**

- **Sander or grinder sparks**

The filter cloth of the dust collector is flammable. The filter cloth may be ignited by a spark, causing a fire.

If a fire occurs in the dust collector, immediately turn the switch off and supply fire extinguishing agents, which are suitable for the dust particles to be suctioned, to the intake port. After that, block both the intake port and exhaust port. Do not open the front door until the temperature inside the dust collector lowers.

- **Flammable gases from petrol, thinner, etc.**

Sparks from the incorporated electric components, static and contact of metals can cause an explosion.



Do not operate the Dustrésa with its maintenance door opened because it could be closed by negative pressure inside catching your fingers and/or the motor overloaded.



Do not ride on the Dustrésa because it could be deformed or you could fall.

This dust collector cannot suction metal powder particles such as aluminum, magnesium or titanium dust; grain powder particles such as flour or starch dust; flammable powder dust particles such as wood flour, resin powder particles or carbon dust; or flammable gases. A powder dusts explosion due to static electricity may occur inside the dust collector. When handling these powder dust particles, be sure to use a dust explosion proof model.

The design service life of this product is eight years except excluding its consumable parts. When the product is used for an extended period exceeding the design service life, the risk of failure or malfunction increases.

Caution



The Dustrésa should not suck the following things which can cause it a failure:

- **Hot gas**

The gas heated to 40°C or more would deteriorate the insulation of electric components inside the dust collector.

- **Water, oil, adhesives and adhesive dust**

They would adhere to the filter cloth causing it blinding.

- **Work, tools and other solid objects than dust**

They could damage the ducts and filter cloth.

- **Particulates** (5 μ or smaller) of carbon and other materials

Use a high-performance filter cloth as the standard type can allow leaks.

- **Lightweight dust** including feather, cotton dust, polystyrene foam dust

They would adhere to the inside of the dust collector.

- **Highly abrasive powder dust particles** such as glass powder particles or polishing agents

Holes may be opened in the filter cloth by abrasion, causing powder dust particles to leak. Furthermore, holes may also be opened in the duct or main unit.



Do not apply high pressure on the Dustrésa with a pressurizer.



Do not use an inverter or other devices to increase the speed of operation. It may cause damage to the blower.



For models with a built-in motor protection device (refer to applicable model), if the motor stops due to overheating caused by an overload, turn of the power immediately. The motor is designed to automatically restart when the motor cools down, which is dangerous. Make sure the cause of the motor overload solved, confirm the motor has cooled down and switch the power on again to start it up.

Applicable model: CFA-110 (Custom-made products may vary depending on the specifications.)



Handle powder dust particles collected by the dust collector correctly according to the national or local governmental regulations in the same manner as disposal parts such as old filter cloths to which powder dust particles are adhered, except when reusing them.

In addition, when disposing of a dust collector that is no longer used, remove powder dust particles adhered to the main unit and recycle the unit as metal waste. Handle other parts to which powder dust particles are adhered according to the relevant laws.

This dust collector operates based on the assumption that the particle diameter of the target dust is 5 μ m or more with the standard filter cloth and 1 μ m or more with the optional high performance filter cloth. The dust amount is 1 g or less for an air volume of 1 m³/min. If the dust collector suctions powder dust particles exceeding this range, dust leakage, increase in filter cloth pressure loss, or clogging may occur.

Chapter 2 Outline of the dust collector

This dust collector is used for separate and collect the airborne dust during processing or powder handling. It is not designed to feed a large amount of powder in a short period. Dust removal also cannot be performed during operation. If the collecting efficiency drops due to clogging, stop operation, and perform the dust removal operation. Continuous operation is not possible.

Configuration

The dust-containing air sucked from the inlet port is dispersed and led to the filter cloth that purifies the air. The purified air goes through the blower and released from the outlet in the machine roof into the atmosphere. The dust caught on the filter cloth is shaken off with a shaker operated by a handle. The dust is collected in the dust pan that is easily taken out from the front door.

Components

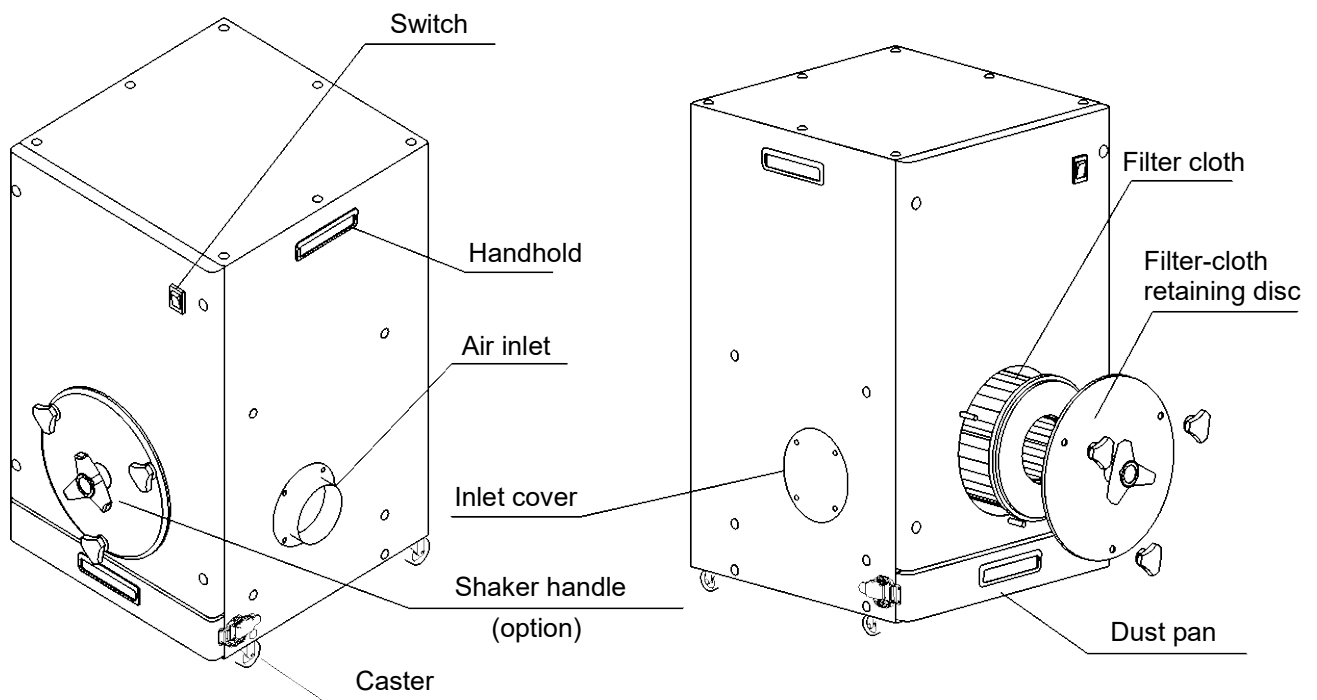

CFA-110

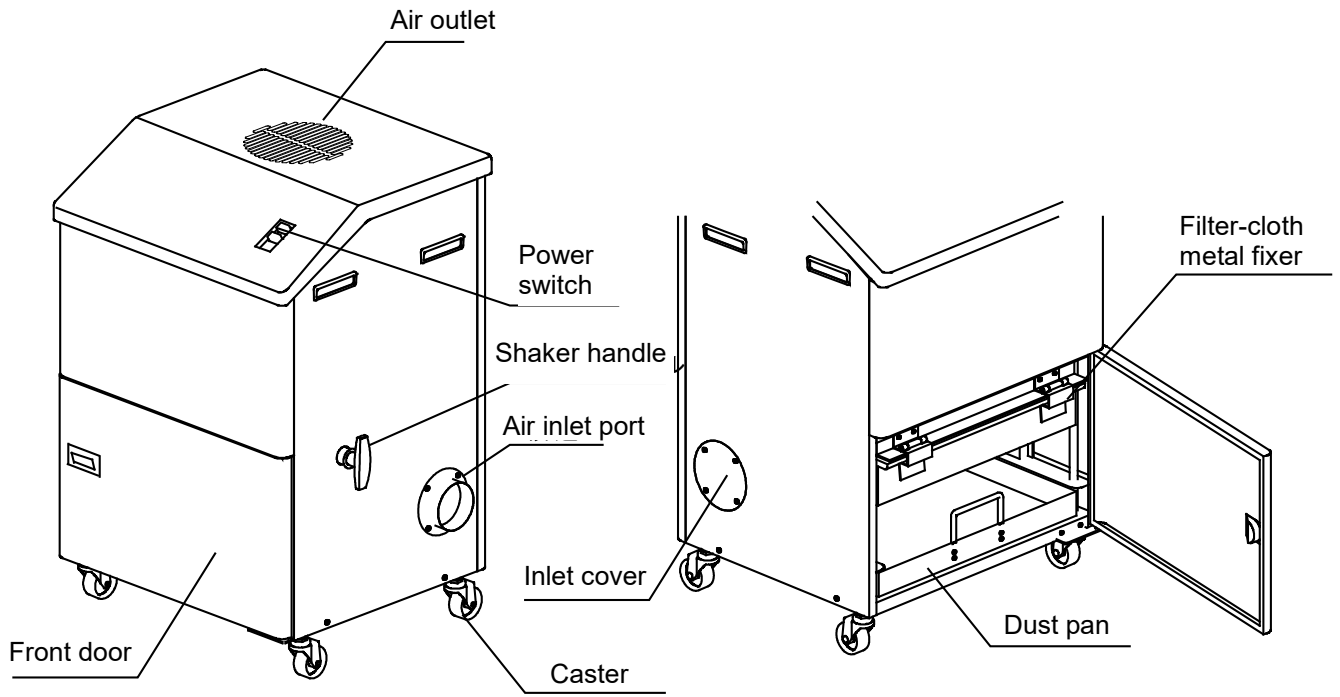

CFA-H215C/T, H220

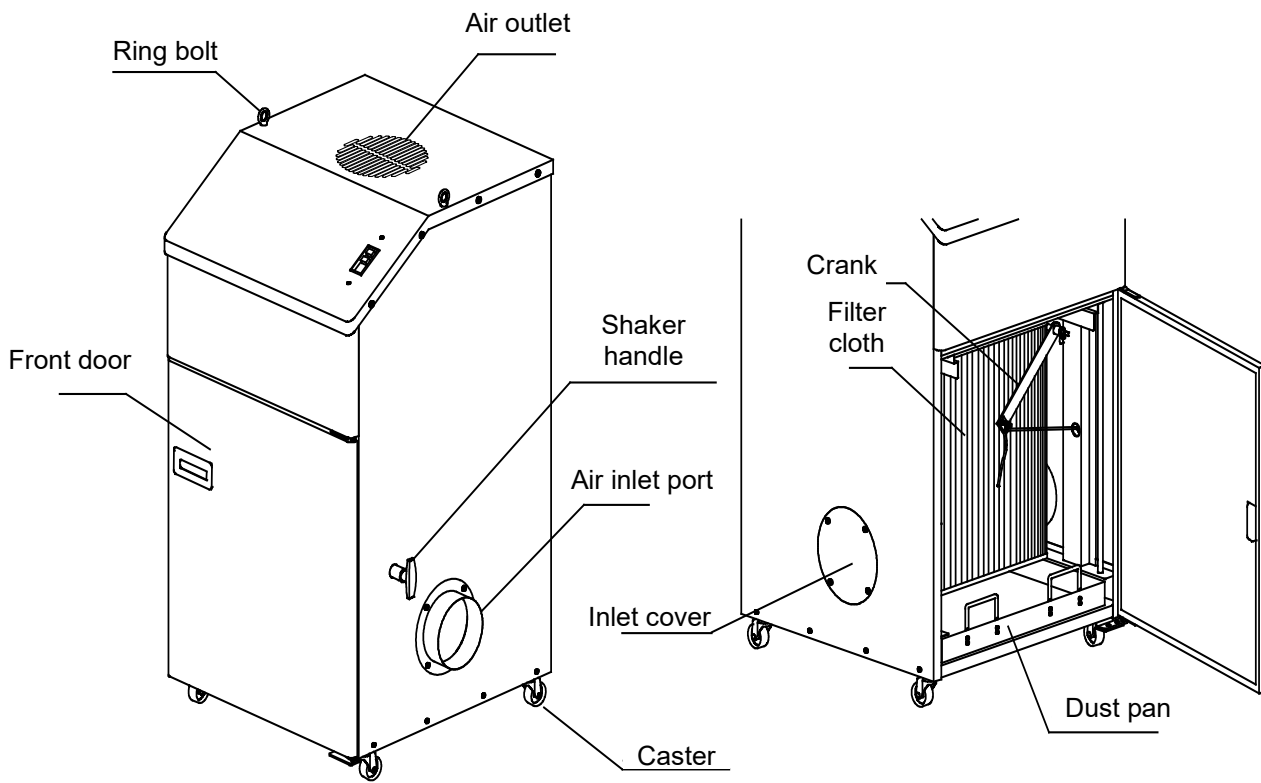

CFA-H240

Chapter 3 Installation

Upon receiving the product, please examine its nameplate to see if the type, voltage and frequency indicated on it conform with those of the ordered product. Also, check up the accessories for conformity.

In case of any damage to the product caused during transportation or a shortage of parts, please immediately contact the relevant retailer or a nearby branch or sales office of Showa Denki.

Please dispose of any unneeded packing materials properly according to local ordinances.



Install the dust collector in a place fulfilling the following conditions:

Indoor places not get wet by rainwater

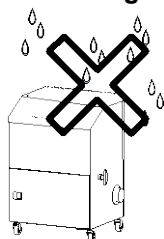

Dust collectors in the CFA series are designed for indoor use.

For installation, avoid places liable to get wet that may induce an electric shock and a product failure.

No dew condensation at room temperature

Ambient temperature: 5°C to 40°C

Humidity: not higher than 80%

High temperatures and dew condensation could cause an electric component failure and/or an electric shock.

Horizontal places free from vibrations

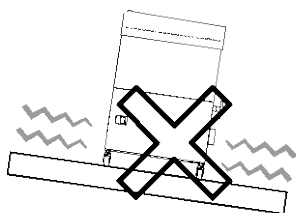

Unusual vibrations could cause the product to topple over.

No hazardous chemicals stored around

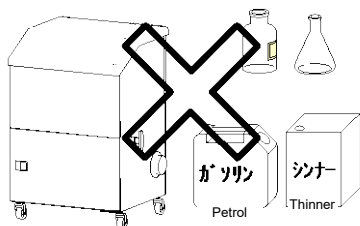

Places close to stored petrol, thinner, and other flammable chemicals have the possibility of an explosion and/or a fire.

Places near the chemicals, like hydrochloric acid and sulphuric acid, that produce a corrosive gas could cause the product to corrode.

Places easy for maintenance

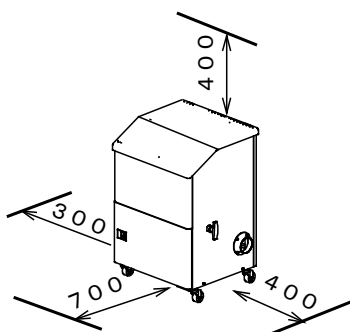

Spaces as illustrated on the left must be secured for dust discharge, filter cloth replacement and purified-air release.

Unit: mm

Installation

- Although the dust collector, equipped with casters, can be readily moved, apply stoppers so it may not move during operation. Avoid using the collector on a slope. When necessary, move it slowly on a flat floor.
- When lifting the CFA-H215C/T or H220, hold the handle on the sides, by two or more persons.
- Ensure an enough space (twice or more as its air outlet diameter) around the dust collector so it may display adequate suction power with its air outlet not blocked. Place nothing on the machine.

Electrical wiring



- Only qualified persons should work on the electrical wiring of the dust collector pursuant to the Electrical Equipment Technical Standards and the Internal Wiring Regulations.
- Make sure of the machine's power supply as per its nameplate and use what is specified therein. Operating the machine on a different power supply could be very dangerous causing an operation failure.
- Use an appropriate fuse (breaker) for the power supply that conforms with the start-up current.
- CFA-H220(50Hz) does inverter control inside. Please do not be connected to other inverter output.
- Be sure to earth the power supply connection.

Model	100V 50Hz Single-phase	100V 60Hz Single-phase	200V 50Hz 3-phase	200V 60Hz 3-phase	220V 60Hz 3-phase
CFA-110	3.5A	3.5A			
CFA-H215C	6A	7.8A			
CFA-H215T			2.3A	2.3A	2.1A
CFA-H220			3.4A	3.3A	3.1A
CFA-H240			6.1A	6.1A	5.6A

Hood and connection of the duct

- The suction air velocity (capture velocity) at the capture point specified in the dust regulations depends on the type of hood. It also depends on the type of dust and the dispersal conditions, it is necessary to design the hood so that an appropriate air velocity can be obtained. The air velocity in the duct should be such that dust does not remain in the duct.
- The duct joints should be tightly sealed so no air may be sucked or leaked through them.
- In case a flexible duct is used, it should not be bent too sharp or unnecessarily sagged so it may keep a high suction power.
- The air inlet port is on the right flank of the collector, viewed from its front door, in the ex-factory configuration. It can be changed to the left flank and the port and the inlet cover may thus be interchangeable.

Standard inlet diameter

CFA-110 CFA-H215C/T	CFA-H220	CFA-H240
φ75 mm	φ97 mm	φ148 mm

Trial operation

- Before a trial run of the dust collector, make sure:
 - that the power supply cable, earth cable, insulation and voltage have been arranged as specified;
 - that there is no air leak at duct joints or no remaining material, bolt, nut or tool left behind in the duct, and
 - that the maintenance door and the dust pan are securely closed.
- With the above points confirmed, turn on the power switch and turn it off quick and observe the motor cooling fan through the air outlet on the ceiling. If it turns clockwise, it is alright. If it turns counter-clockwise, then turn off the power supply and change the connections of 2 cables of the 3 power supply cables. (Excluding single-phase models)

Chapter 4 Operation

Routine operation

Operation procedures: [1] Make sure that the front door is closed.
[2] Turn on the power switch to start operation.

End operation procedures: [1] Turn off the power switch.
[2] Wait about 2 minutes and then shake off the deposited dust on to the dust pan and discharge.

- Since continuous operation of the dust collector would blind the filter cloth and cause the suction power to drop, stop operating the machine and go through the shaking-off and discharge steps.
- During operation, the shaking-off and discharge procedures are disabled.
- Discharge of dust should be performed at the end of the day's operation. During this procedure, be sure to wear protective goggles and gloves and a dustproof mask.



How shake off the dust

CFA-110

Detach and clean the filter cloth.

If equipped with an optional shake-off device, turn its handle to shake off the dust.

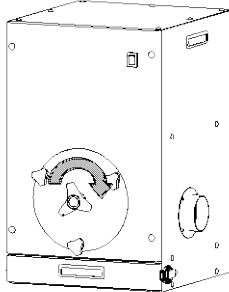

CFA-H215C/T, H220, H240

While holding the collector body by hand, pull the shaker handle about 3 times. After use, return the handle to its original position so it may not sag.

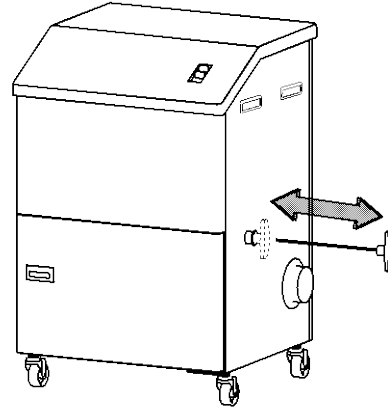

Caution

- When operating the power switch, press it quick and securely. Insufficient switch operation could induce a machine failure due to heating and damage caused to the machine.
- Although, in case of fine dust, a small amount can leak from the dust collector at its start, this phenomenon will disappear when dust deposits on the filter cloth overall. If, however, the leakage continues, replace the cloth with the optional high-performance type.
- Since continuous operation of the machine would weaken its suction power due to the blinding of the filter cloth, stop the machine and Please perform operation to shake off.
- The dust pan, fixed in position with spring, can somewhat hitches on its casing when drawn in or out. When returning the pan into position, push it in until it clicks fixed (except CFA-110).
- Clean the pan before it accommodates too much dust.
- It is not possible to shake off or discharge dust during operation.
- When the day's operation is over, dispose of the dust. Wear protective glasses, a dust mask, and gloves when disposing of dust.
- The filter cloth's life is one to two years on the average, which, however, depends on the machine's operation time and dust attributes and concentration. Replace the cloth with a new one if the shake-off procedure fails to recover the suction power.
- Although the filter cloth may not be damaged by usual operation, stop the machine operation and replace the cloth with a new one if it is damaged. Using a damaged filter cloth could not only allow dust to be released into the atmosphere but damage the built-in blower as well.
- Handle powder dust particles collected by the dust collector correctly according to the national or local governmental regulations in the same manner as disposal parts such as old replaced filter cloths, except when reusing them.



Chapter 5 Maintenance



Be sure to maintain the dust collector at regular intervals. This is important to prevent the machine's failure or accident and keep it serving you for many years to come. During the maintenance work, always turn off the power supply to the machine and when replacing the filter cloth use protective goggles and gloves and a dustproof mask. Perform maintenance and inspections following the occupational safety regulations of your country.

What and when to inspect

What	When	Description
Front door	Before operation	Must be securely closed.
Dust pan	↑	Dust must be disposed.
Motor load current	Once a day	Read the control panel ammeter, etc.
Exhaust air	↑	Dust must not leak.
Blower vibrations	↑	No vibrations or noise
Shaker	↑	No noise or operation error
Filter cloth application	Once a month	Cloth must not come off, loosen or damage.
Piping	↑	No bolt coming off or loosened or no worn-off packing
Ducting	↑	No dust deposits or clogs
Electrical wirings	↑	No poor insulation or loosened terminal
Inside of the machine	One a year	Clean the components of adhered dust.
The machine and its casing	↑	No corrosion or gap

Replacing the filter cloth

CFA-110

- (1) Remove the 3 knobs from the filter-cloth retaining disc.
- (2) Detach the retaining disc and remove the old cloth.
- (3) Insert a new cloth and fix the filter into the guide pins.
- (4) Secure the retaining disc with the 3 knobs.

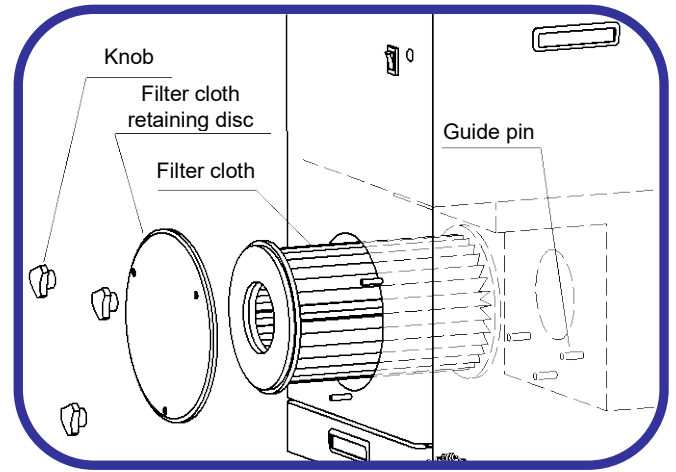

CFA-H215C/T, H220

- (1) Raise the filter-cloth metal fixers

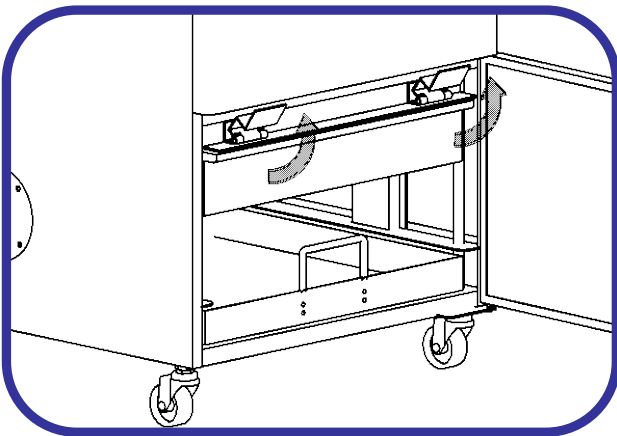

- (2) Draw out the filter cloth to this side and take it out.

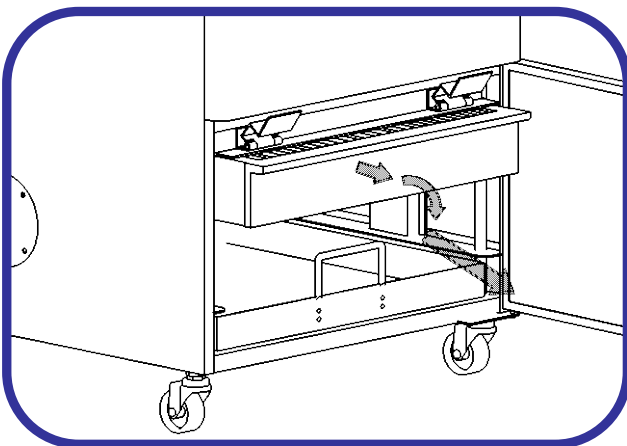

CFA-H240

- (1) Remove the crank by loosening the rope retaining screw and the wing nut. Draw out the dust pan.

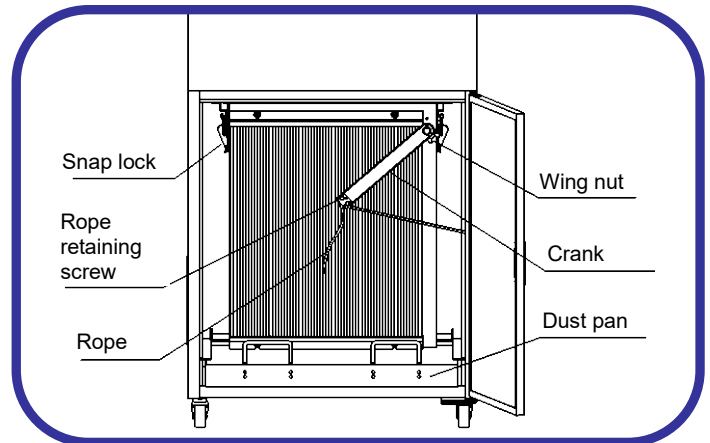

- (2) Unlock the snap locks located on both upper sides of the filter case and pull out the case to this side.

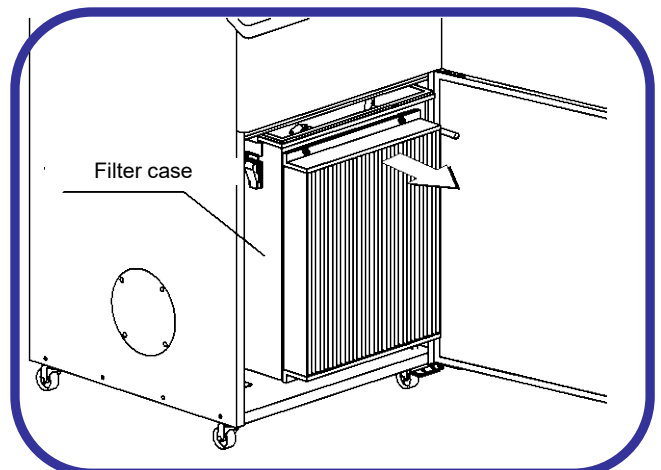

- (3) Insert a new filter cloth in the direction as shown in the figure below, make sure that the cloth is inserted in the back groove and push it into position completely.

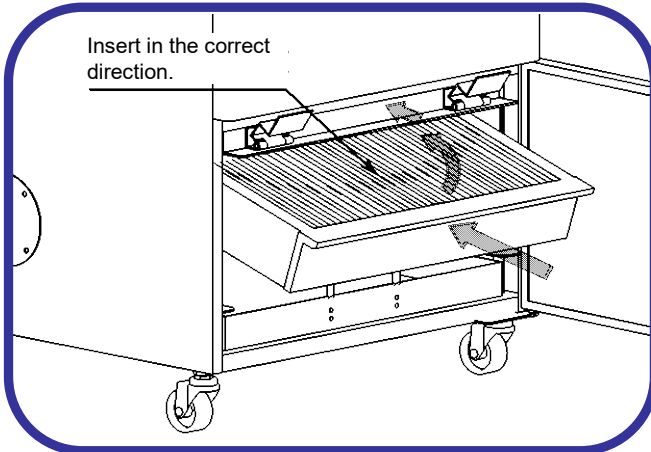

- (3) Loosen off the M6 nuts that fix the filter cloth and remove the cloth.

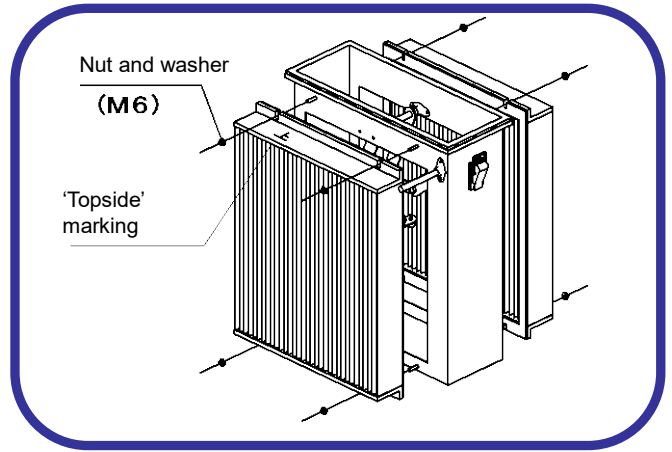

- (4) Pull up this side of the filter cloth and secure it in position with metal fixers as it was.

- (4) Attach a new cloth, with the 'Topside' marking facing up, and assemble the whole thing reversely to the procedures mentioned above. Adjust the rope's tension (See next page).

Adjusting tension of the shaking rope

Regulate the tension of the shaking rope if the shaker handle is loosened too much or when the filter cloth is renewed.

- (1) Loosen the 2 rope-retaining wing bolts and make the shaker handle closely contact the machine body.
CFA-H215C/T, CFA-H220 (Remove the filter cloth.) CFA-H240

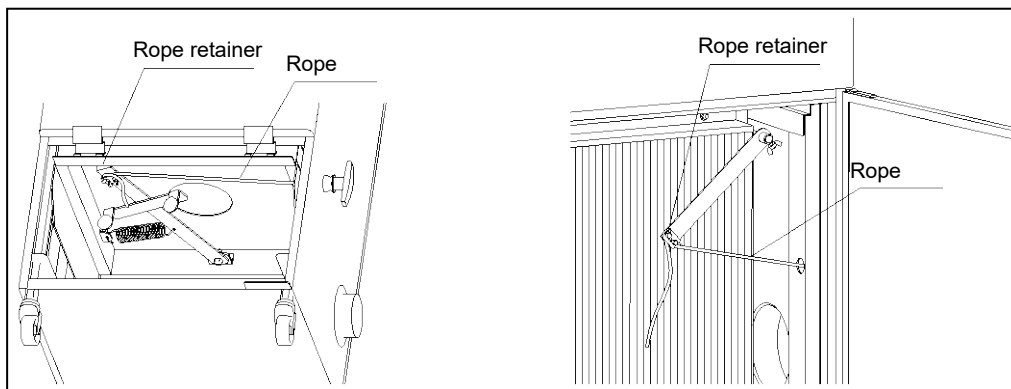

- (2) While pulling the rope end, turn the rope retainer by 2 to 3 cm in the arrow-marked direction.

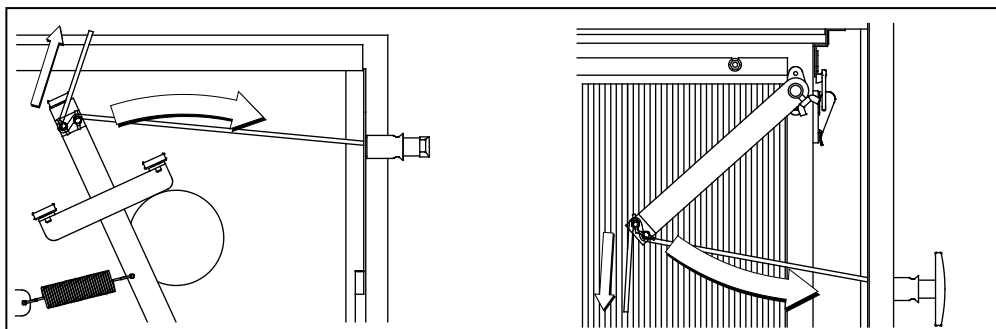

(3) While pulling the rope, fasten the rope-retaining wing bolt.

Rope retainer in detail

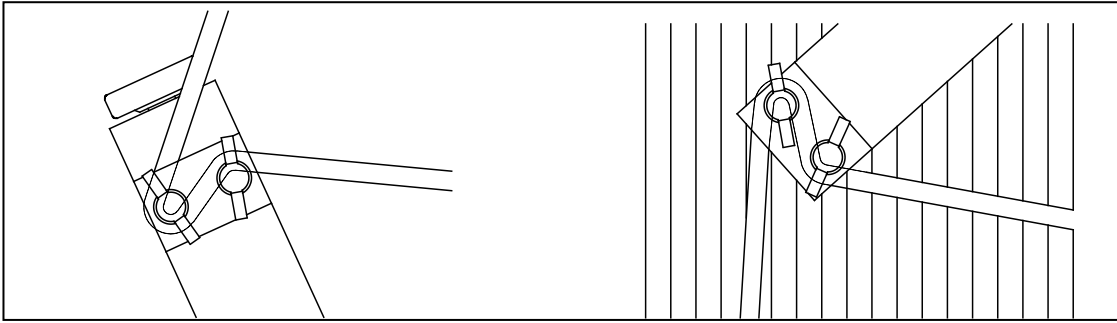

Note: There can be a little air leak from the rope-pierced portions when the rope tension is regulated, which, however, may not affect the machine's performance.

In case the rope is broken or severely worn out, replace it with a new one.

Rope for replacement	Starter rope (nylon solid braided)	$\phi 4 \text{ mm} \times 50\text{--}60 \text{ cm}$
----------------------	---------------------------------------	---

The rope is commercially available.

Replacement filter cloth sizes

Type	Cloth size	Number of cloths applied
CFA-110	$\Phi 150 \text{ mm} \times 250 \text{ mm}$	1
CFA-H215C/T	420 mm x 420 mm x 75 mm	1
CFA-H220	420 mm x 420 mm x 95 mm	1
CFA-H240	420 mm x 540 mm x 75 mm	2

Use our genuine filter cloths for replacement.

During replacement work, be sure to wear protective goggles and gloves and a dustproof mask.

Troubleshooting

Symptom	Possible causes	Remedies
Blower motor fails to start.	<ul style="list-style-type: none"> • Power absent • Thermostat activated • Motor failure 	<ul style="list-style-type: none"> • Turn on the power supply. • Turn off the switch, determine the cause(s), remove it (them) and restart. • Inspect and repair the motor (Consult the manufacturer).
Blower noise, unusual vibrations	<ul style="list-style-type: none"> • Broken motor bearings • Foreign matter mixed • Impeller out of balance 	<ul style="list-style-type: none"> • Replace the bearings. • Remove the foreign matter. • Clean the impeller. <p>Correct the imbalance (Consult the manufacturer).</p>
Blown dust leakage	<ul style="list-style-type: none"> • Broken filter cloth • Filter cloth mounting error • Packing worn off • Dust particles too fine 	<ul style="list-style-type: none"> • Replace the filter cloth. • Remount the filter cloth. • Replace the packing with a new one. • Replace the filter cloth with a higher-performance version.
Poor suction power	<ul style="list-style-type: none"> • Damper closed • Inlet piping clogged • Filter cloth blinding • Using both side of suction port 	<ul style="list-style-type: none"> • Open the damper. • Clear deposit from the piping. • See the following item. • Please make piping branch only on one side of suction port and pipe it again.
Filter cloth blinding	<ul style="list-style-type: none"> • Filter cloth's life • Adverse dust attributes 	<ul style="list-style-type: none"> • Replace the cloth with a new one. • Effective measures should be taken separately.
	<ul style="list-style-type: none"> • Too much quantity of dust 	<ul style="list-style-type: none"> • Please install pretreatment device like cyclone, sedimentation box etc.
	<ul style="list-style-type: none"> • Because of too high filtering speed, dust enters into the meshes of filters and cannot be removed by dust removing system. 	<ul style="list-style-type: none"> • Control suction amount by using damper etc.

Specifications

Note: The noise levels were measured at 1 m from the machine's front, which may vary depending on the environment and condition in which to use the machine.

Model	Motor kW	Airflow rate m ³ /min	Static pressure kPa	Filtration area m ²	Dust container capacity L	Noise level dB(A)	Mass kg
CFA-110	0.2	4	0.8 (50 Hz) 1.18 (60 Hz)	0.8	3.1	64	25
CFA-H215C	0.4	4 5 6	2.10 1.76 1.37	1.5	6.9	64	47 (50 Hz) 44 (60 Hz)
CFA-H215T	0.4	4 5 6	2.20 1.86 1.47	1.5	6.9	64	49 (50 Hz) 47 (60 Hz)
CFA-H220	0.75	6 8 10	2.45 2.15 1.72	2	6.9	65	59
CFA-H240	1.5	12 16 20	2.65 2.45 2.06	4	16.9	68	135

Outside dimensions (mm) CFA-110

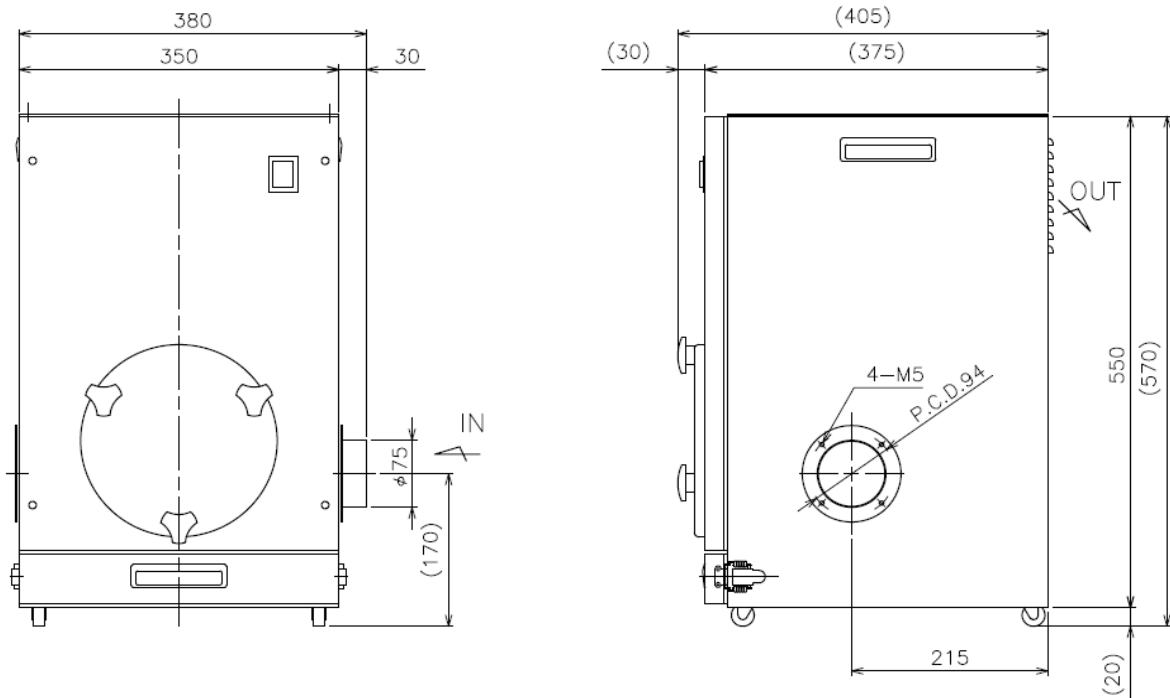

Outside dimensions (mm)

CFA-H215C/T, CFA-H220

(The numeric values in brackets □ show the dimensions of the H220)

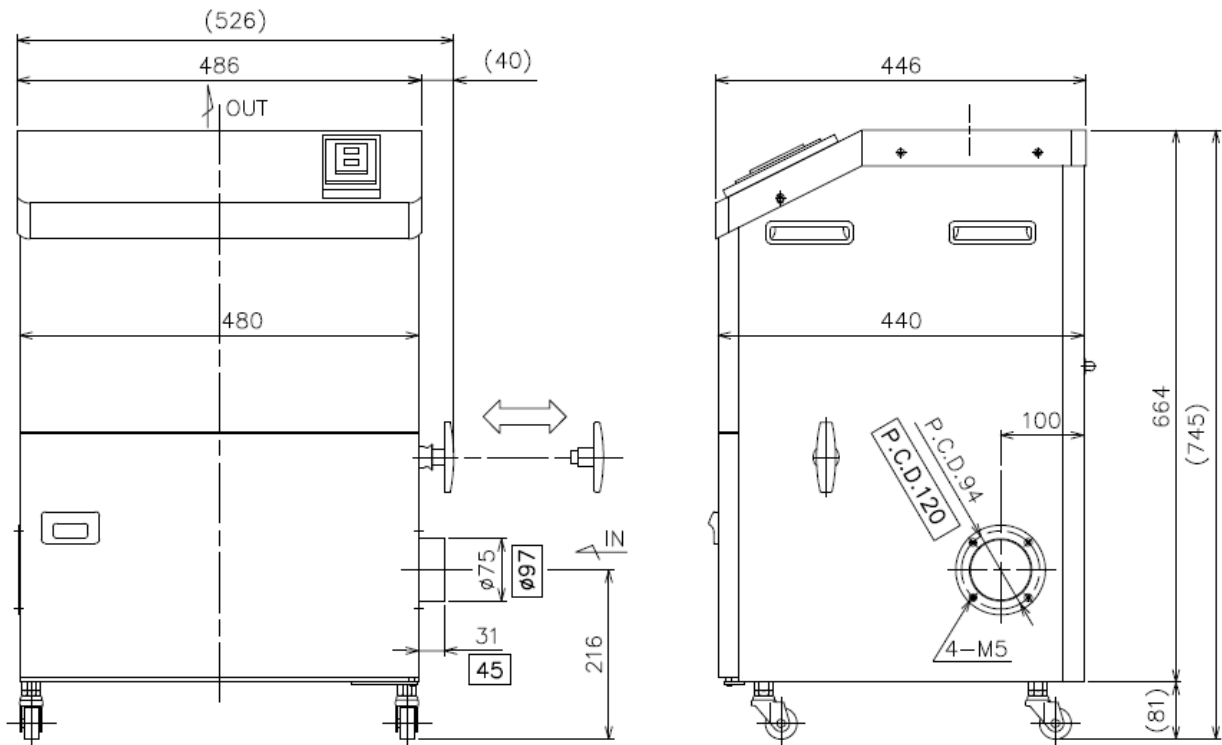

Outside dimensions (mm)

CFA-H240

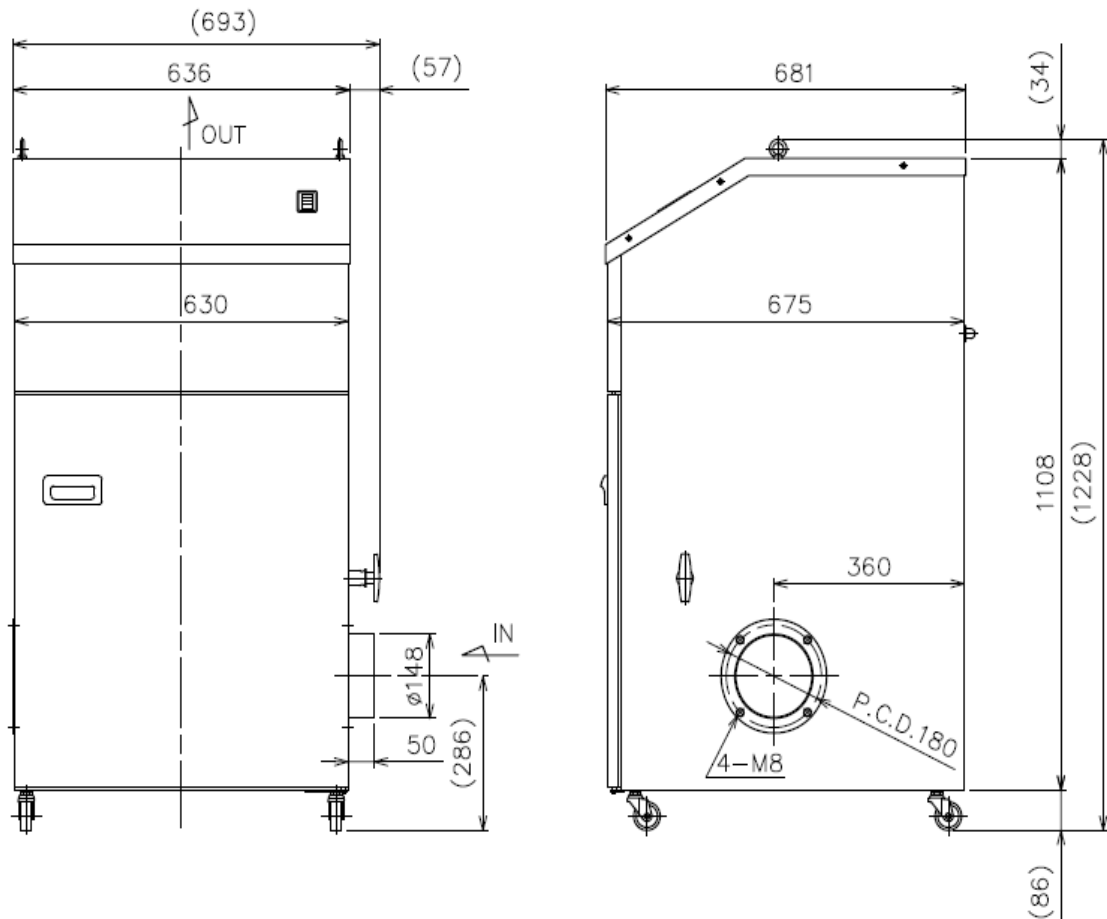

Chapter 6 Warranty

Scope of warranty

In the case of any malfunction and/or breakage/damage that occurs under normal conditions (under our Instruction Manual) within the warranty period, exchange and/or repair will be performed by our company free of charge based on the contents of this provision.

Warranty period

One (1) year from the date of delivery of the product.

Even during the warranty period, only charged service is provided in principle, if any of the following applies:

- Failure or damage due to incorrect use that is not compliant with these Operating Instructions, labels attached to the body, or other instructions, and/or unauthorized repair or modification
- Failure or damage due to transportation, dropping, etc. after the purchase
- Failure or damage due to fire, earthquake, storm, flood, lightning or other natural disasters, environmental factors such as salt damage and public pollution, abnormal voltage, use of a power supply (voltage or frequency) other than that specified, or the like
- Failure or damage due to repair or modification (including punching, etc. in the product) not conducted by our company
- Failure or damage due to the use of parts other than those designated by our company
- Trouble when I absorbed the dust except the meeting and the damage
- The trouble that damage of the filter cloth and the packing that happened by having absorbed a sharp material depends on and the damage
- Discoloration, scratching, natural consumption of consumable parts or other defects due to use or deterioration over time
- Failure or damage caused by neglecting the maintenance and inspection described in the Operating Instructions
- Expendable supplies including the filter cloth and packing

※[Notices]

- (1) The descriptions in these Operating Instructions are subject to change without prior notification in the future.
- (2) We have made all possible efforts to prepare these Operating Instructions. However, if you have any questions about them or find any inquiries, errors, omissions, etc., please contact our nearest branch or sales office.
- (3) If the power supply frequency changes due to a change in the location where the blower is used, it may not be used as it is. We will consider a measure in each case where it is required. In such a case, please contact our nearest branch or sales office.
- (4) At the time of inquiry, please describe the product type and the manufacturing number indicated on the product nameplate.

Notes : We are not responsible for any accident or breakdown caused by different/wrong use from this manual, and improper repair or remodeling.



Business Promotion Dpt.

1-25 Shinden Kita-machi, Daito-city, Osaka, Japan 574-0052

Tel: +81-72-870-5708 Fax: +81-72-870-7243

Email: sales@showadenki.co.jp

<http://www.showadenki.co.jp>