

ヒュームコレクタ Fume Collector

取扱説明書 Instruction Manual

型式／MODELS

| | |
|---------------------|------------|
| CKU-060AT3-ACC | (100V) |
| CKU-060AT3-ACC(-T) | (200V) |
| CKU-060AT3-ACC(-CE) | (220-230V) |



- 取扱説明書(以下、本書といいます)の『製品使用上のご注意』の内容をよく理解し、本書をよく読んでから操作してください。
Please understand well the contents of "Cautions on Product Use" of Instruction Manual (hereinafter referred to as "this manual"), and operate it after often reading this manual.
- 本書はいつでも使用できるよう、大切に保管してください。
Please keep this manual carefully to be able to use it at any time.

■はじめに／Introduction

このたびは、お買い上げ頂き、誠にありがとうございます。

チコーエアートック株式会社は「風の技術」を有効に利用し、コンパクトに空気をクリーンにすることをテーマとして努力しております。

この製品は、この風の技術をコンパクトにまとめた省エネ形のクリーン BOX です。

長期間故障なく安全にご使用いただくために、この取扱説明書をよくお読みいただき、本機の性能を十分に発揮できますよう正しいお取り扱いをお願いします。

We greatly appreciate that you have purchased our dust collector.

CHIKO AIRTEC CO., LTD. is working to achieve clean air with compact equipment while utilizing “air technology” effectively.



This machine is an energy-saving-type clean box that realizes “air technology” in a compact body.

Please read this instruction manual thoroughly and handle this machine correctly so that you can use it safely for a long time and enjoy its full performance.

■本文中の表記について／About Notation

本書では、以下の表記に従って説明しています。

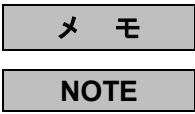
This manual explains according to the following notations.

| 表記／Notation | 意味／Description |
|---|--|
|  | 本機の機能を十分に発揮するための情報や、本機の損傷を防ぐための情報を記載しています。 The information for fully exhibiting the function of this machine and the information for preventing damage to this machine are indicated. |
|  | 参考となる情報を記載しています。 The information which is consulted is indicated. |
| 1. 2. 3. ... | 操作手順を記載しています。 The operating procedure is indicated. |
|  | 参照先を記載しています。 The reference destination is indicated. |

■転載・複写について／Copyrights

- 本書の著作権は、チコーエアートック株式会社が所有しています。
CHIKO AIRTEC CO., LTD. owns the copyright of this manual.
- 本書の内容の一部あるいは全部の無断転載や複写は固くお断りします。
Unauthorized reproduction or copying of part or all of the content of this manual is strictly prohibited.
- 本書の内容は、将来予告なく変更することがあります。
The contents of this manual are to change without notice.

Table of contents

| | |
|---|-----------|
| Chapter 1 Product Usage Precautions | 3 |
| 1.1 Safety Notations | 3 |
| 1.2 Precautions for Transport, Storage, and Relocation..... | 3 |
| 1.3 Precautions for Installation | 3 |
| 1.4 Precautions for Operation | 4 |
| 1.5 Other Precautions | 4 |
| 1.6 Safety Label Locations | 5 |
| Chapter 2 Components Identification | 6 |
| 2.1 Accessories | 6 |
| 2.2 Device Body | 7 |
| 2.2.1 CKU-060AT3-ACC..... | 7 |
| 2.3 AT3 Panel | 8 |
| 2.4 Display Indications | 9 |
| 2.4.1 About Modes..... | 9 |
| 2.4.2 Indications During Stoppage | 9 |
| 2.4.3 Indications During Operation..... | 10 |
| Chapter 3 Operation | 11 |
| 3.1 Start-up Preparation | 11 |
| 3.1.1 Installation | 11 |
| 3.1.2 Wiring and Piping | 12 |
| 3.2 Operation..... | 12 |
| 3.3 Registering Initial Pressures | 13 |
| Chapter 4 Configuring Settings (MODE SELECT Mode) | 14 |
| 4.1 Screen Transitions in MODE SELECT Mode..... | 14 |
| 4.2 Communication Format Setting Mode (When Equipped with Communication Function) | 14 |
| 4.3 Air Volume-Down Alert Timing Setting Mode | 15 |
| 4.4 Other Setting Mode | 15 |
| 4.4.1 Clock Calibration Mode | 15 |
| 4.4.2 Accumulated Run Time Reset Mode..... | 16 |
| 4.4.3 Setpoint Reset Mode | 16 |
| 4.5 Error History Mode | 16 |
| Chapter 5 Maintenance and Checkup | 17 |
| 5.1 Replacing Filters..... | 17 |
| 5.1.1 Replacing the Primary filter..... | 17 |
| 5.1.2 Replacing the secondary filter..... | 18 |
| 5.1.3 Replacing the tertiary filter..... | 18 |
| 5.2 Replacing Fuse..... | 19 |
| 5.3 Replacing the Button Battery | 20 |
| 5.4 Daily Checkup | 20 |
| 5.5 Errors/Warnings..... | 21 |
| 5.5.1 Action on Errors/Warnings..... | 21 |
| 5.5.2 Error/Warning Table..... | 22 |
| 5.6 Troubleshooting..... | 23 |
| Chapter 6 Useful Utilization (Optional) | 24 |
| 6.1 Remote Cable..... | 24 |
| 6.1.1 Electrical Diagram | 24 |
| 6.1.2 Pin Assignments..... | 26 |
| 6.1.3 Remote Operation | 27 |
| 6.2 Communication Function..... | 27 |
| 6.2.1 RS485 Communication | 27 |
| 6.2.2 Ethernet..... | 27 |

6.3 Removable Flange 27





Chapter 7 Appendix 28

7.1 Specifications 28
7.2 Consumables List 28
7.3 Electrical Diagram 29
 7.3.1 CKU-060AT3-ACC 29





Chapter 1 Product Usage Precautions

1.1 Safety Notations





This instruction manual describes usage precautions with the below listed symbols. Be sure to read the instructions.

| Symbol | Meaning |
|--|--|
|  WARNING | Indicates a hazardous situation which, if not avoided, could result in personal death or serious injury. |
|  CAUTION | Indicates a hazardous situation which, if not avoided, could result personal injury or damage to the device. |
|  | Indicates a prohibited action (which MUST NOT be done). |
|  | Indicates a mandatory action (which MUST be done). |



1.2 Precautions for Transport, Storage, and Relocation



| | | |
|--|---|---|
|  WARNING |  | <ul style="list-style-type: none"> Transportation must be done using at least two people. Injury may result due to fall hazard. |
|  CAUTION |  | <ul style="list-style-type: none"> Relocation and storage must be done in a safe location within the temperature range of -10°C to 60°C at relative humidity of 80% or less. |

1.3 Precautions for Installation



| | | |
|--|---|--|
|  WARNING |  | <ul style="list-style-type: none"> Do not install the device in or around an area with flammable, explosive, or corrosive mist, smoke, or gases. |
|  CAUTION |  | <ul style="list-style-type: none"> This device is designed for installation in a cleanroom or a clean factory. Avoid installation in other areas, such as outdoors. Ensure a wide suction port. If the device is used continuously with a narrow suction port (i.e., at high pressure), the motor may become hot as it cannot be cooled. |
| |  | <ul style="list-style-type: none"> Install the device in a horizontal, vibration-free location as it contains rotating equipment. Install the device at normal temperature (ambient temperature 0°C to 40°C, at humidity 80% or less) without dew condensation. High temperature or dew condensation may cause failure of electrical components or electric shock. Beware that suction ambient temperature (temperature around the dust to be collected) is low enough, because otherwise the motor may lead to performance reduction or failure. The installation site should be at an altitude of 1,000 m or less. |



1.4 Precautions for Operation

| | | |
|--|---|--|
|  WARNING |  | <ul style="list-style-type: none"> Do not suck the following substances: Flammable substances... Gasoline, thinner, benzene, kerosene, paints, etc. Explosive dusts Aluminum, magnesium, titanium, zinc, epoxy, etc. Sparky dust Dust containing sparks from high-speed cutting machine, grinder, welding machine, etc. Fire source Cigarette, and liquid such as oil and chemical Others..... Liquid such as water, oil, chemical Do not use the device in or around an area with flammable, explosive, or corrosive mist, smoke, or gases. Ensure secure connections, without bending or pulling cables with excessive force. Fire or electric shock may result. Ensure that the power supply conforms to the specifications of the device. |
| |  | <ul style="list-style-type: none"> Use the device to suck dry dust without potential dust explosion. Be sure to connect the ground wire. |

| | | |
|--|---|--|
|  CAUTION |  | <ul style="list-style-type: none"> Do not move the device while in operation. |
| |  | <ul style="list-style-type: none"> Use the device in locations of pollution degree 2. Use a power supply of overvoltage category II. Turn off the main power switch in case of power outage. Injury or device damage can occur when power returns. Ensure that filters are installed correctly. If filters are missing, clogged, or broken, foreign matter may enter the motor, causing failure. |

1.5 Other Precautions

| | | |
|--|---|--|
|  WARNING |  | <ul style="list-style-type: none"> Do not disassemble or alter the device. Failure to observe can cause electric shock or injury. For internal checkup or repair, contact your dealer. |
| |  | <ul style="list-style-type: none"> Follow the information in the instruction manual when performing installation, connection, starting, operation, checkup, and fault diagnosis. Working in a wrong manner may lead to fire, electric shock, or injury. |

| | | |
|--|---|---|
|  CAUTION |  | <ul style="list-style-type: none"> When discarding the device, dispose of it appropriately as an industrial waste. |
|--|---|---|

1.6 Safety Label Locations

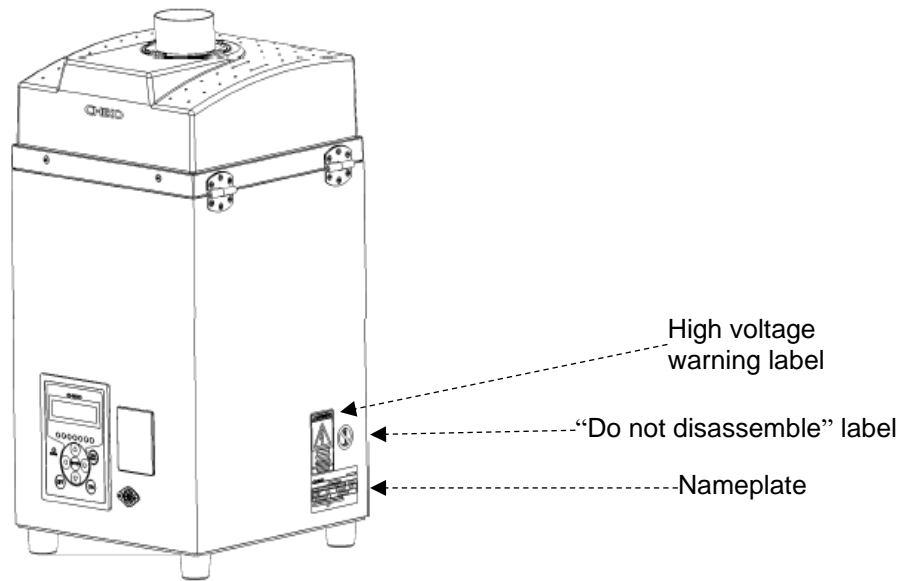

High voltage warning label



“Do not disassemble” label



Nameplate

CHIKO Dust Collector

--**-***

| | | | |
|---------------|---------------|-----------|-------|
| Voltage | ***V | Frequency | */*Hz |
| Current | **A | Mass | ***kg |
| SERIAL NUMBER | 20***-***-*** | | |

CHIKO AIRTEC CO., LTD MADE IN JAPAN
2-27-24 Hakushima, Minoh City Osaka Japan 562-0012

Chapter 2 Components Identification

2.1 Accessories

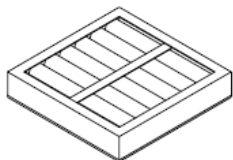

①

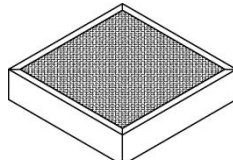

②

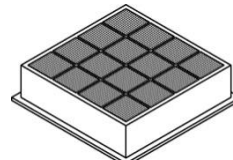

③



④

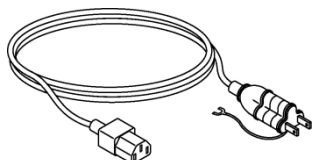

100V version

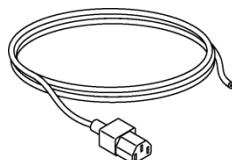

200V version (-T version)

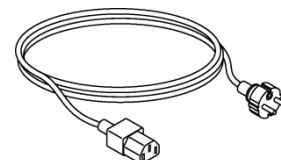

220-230V version (-CE version)

⑤



⑥

| No. | Name | Function | Qty. | |
|-----|--------------------|--|---------------------------------|---|
| ① | Primary filter | Collects/adsorbs dust. | 1 | |
| ② | Secondary filter | Removes odors by trapping fine particles through collision with the activated carbon granules. | 1 | |
| ③ | Tertiary filter | Prevents activated carbon particles from entering into the blower. | 1 | |
| ④ | Removable flange | Connects a suction duct. | 1 | |
| ⑤ | Power cable (3 m) | Connects to the power outlet. | 100V version* ¹ | 1 |
| | | Shaped differently depending on power supply specifications. | 200 V version (-T version) | 1 |
| | | | 220/230 V version (-CE version) | 1 |
| ⑥ | Instruction manual | Provides instructions for using the device. | 1 | |

*1 Can be used in the area of 100-115V.

2.2 Device Body

2.2.1 CKU-060AT3-ACC

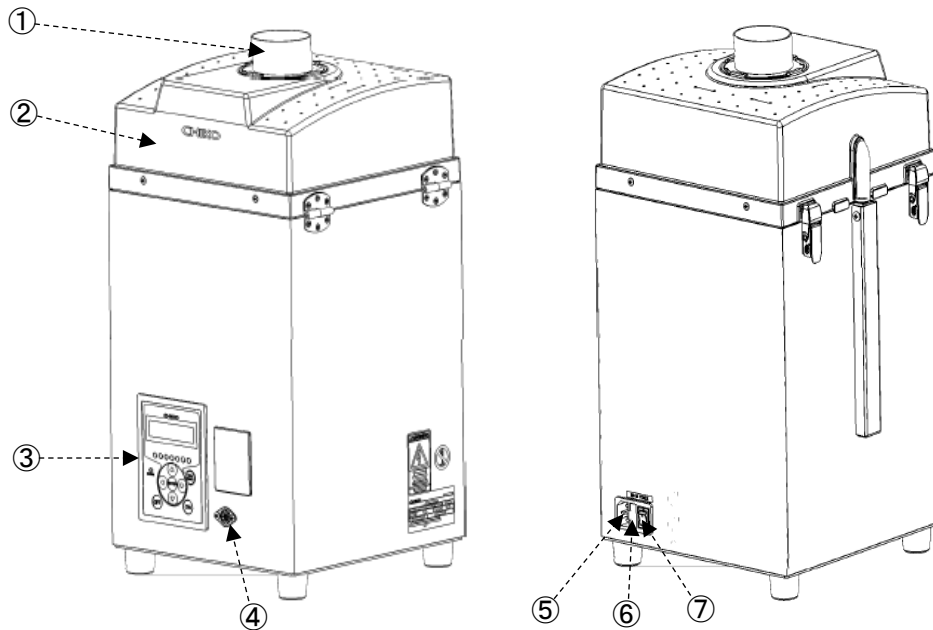

| No. | Name | Function |
|-----|------------------------------------|---|
| ① | Suction port (Removable flange) | Connects a suction duct. |
| ② | Suction-side filter case | Contains the primary filter, the secondary filter and the tertiary filters. |
| ③ | AT3 panel (operation panel) | Operates the device. |
| ④ | Remote connector | Connects a remote cable (optional). |
| ⑤ | Power connector | Connects the power cable. |
| ⑥ | Fuse box | Contains a fuse. |
| ⑦ | Main power switch | Turns on/off power to the device. |

2.3 AT3 Panel

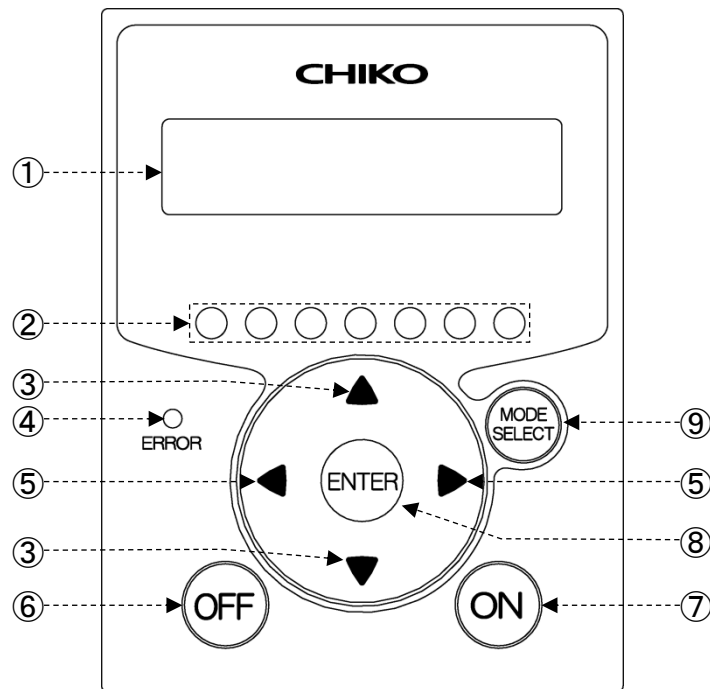

| No. | Name | Function |
|-----|---------------------------|--|
| ① | Organic EL (OLED) display | Displays the operating status and various settings. Displays an error or warning number in case of an error or warning. |
| ② | Suction power level lamps | Green lamps indicate a suction power level (1 to 7). |
| ③ | Up/Down arrow buttons | During stoppage or operation, switches among the content of the display. ☞ “2.4 Display Indications” (page 9) In MODE SELECT mode , cycles through parameters and changes numeric data. ☞ “Chapter 4 Configuring Settings (MODE SELECT Mode)(page14)” |
| ④ | ERROR lamp | The red lamp lights upon detection of an error that stops device operation. The red lamp flickers upon detection of an error or warning that continues device operation. |
| ⑤ | Left/Right arrow buttons | During operation, each pressing of the Left (or Right) arrow button changes the suction power to the next lower (or higher) level. During MODE SELECT mode , each pressing of the Left (or Right) arrow button moves the cursor left (or right) to the next position. |
| ⑥ | OFF button | Stops the operation. During stoppage, holding this button down for three seconds clears the registered initial pressure. ☞ “3.3 Registering Initial Pressures “ (page 13) |
| ⑦ | ON button | Starts operation. |
| ⑧ | ENTER button | During operation, holding this button down for three seconds causes transition to initial pressure registration. ☞ “3.3 Registering Initial Pressures” (page 13) During SELECT MODE mode , determines the selected parameter and its numeric data. ☞ “Chapter 4 Configuring Settings (MODE SELECT Mode)(page14)” |
| ⑨ | MODE SELECT button | During stoppage, transits to the MODE SELECT mode . ☞ “Chapter 4 Configuring Settings (MODE SELECT Mode)(page14)” During MODE SELECT mode, returns to the previous mode. During an error/warning, transits to the error history mode or error clear mode. |

2.4 Display Indications

2.4.1 About Modes

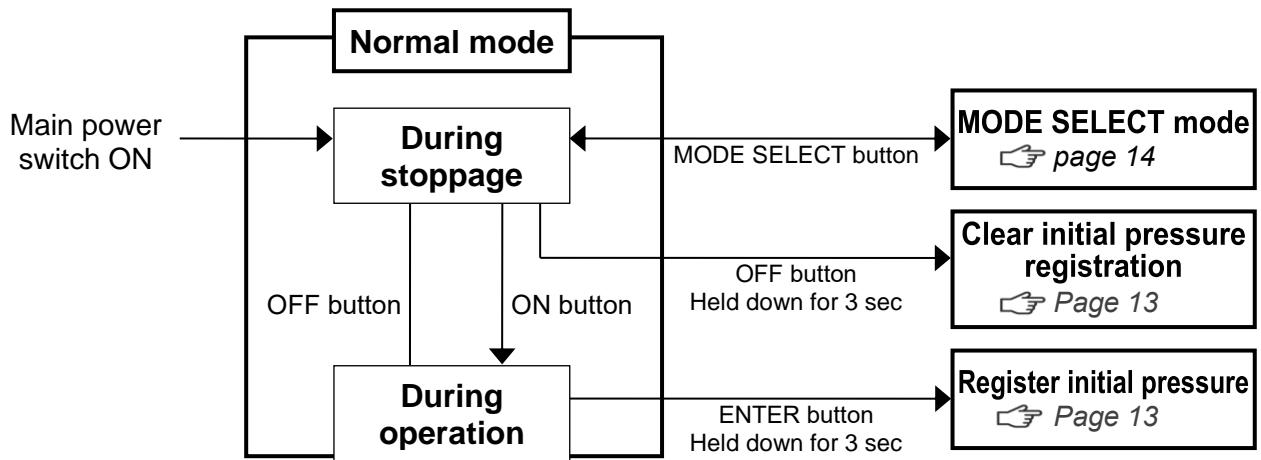

2.4.2 Indications During Stoppage

The Up/Down arrow buttons cycle through indications.

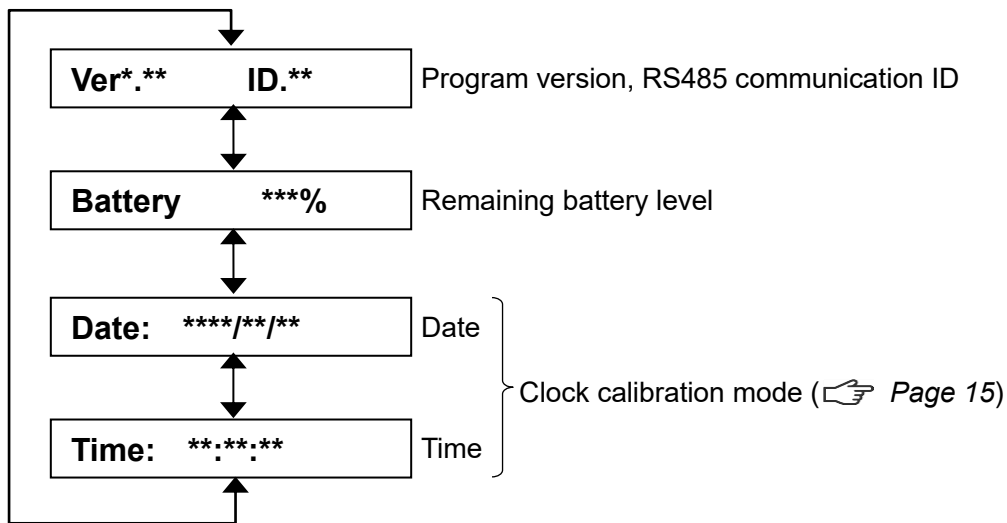

2.4.3 Indications During Operation

The Up/Down arrow buttons cycle through indications.

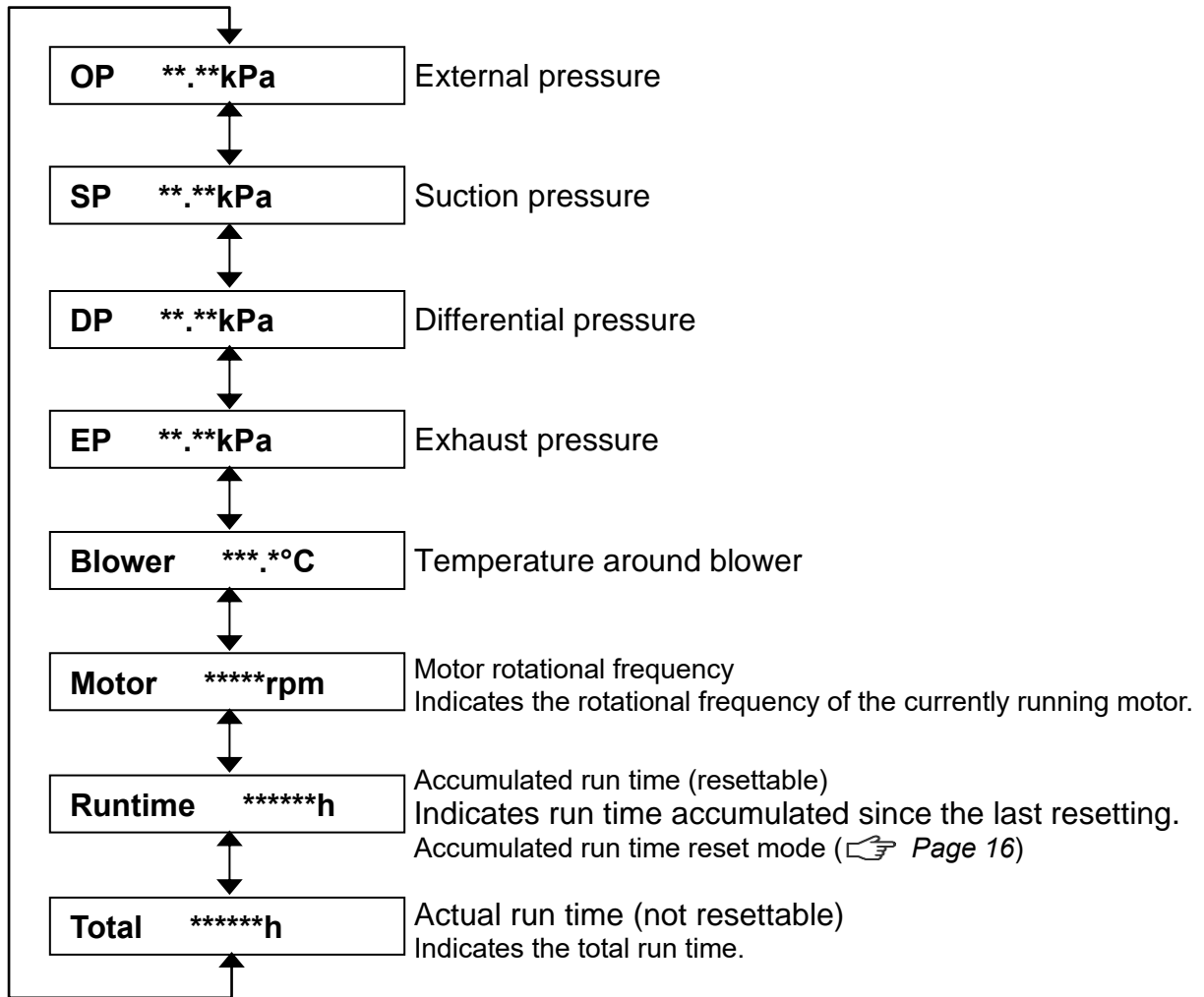

Chapter 3 Operation

3.1 Start-up Preparation

3.1.1 Installation

■ Installation location

To ensure operating safety and deliver the full performance of the device, install the device in a location that meets the following conditions:



| Item | Description |
|---------------------|--|
| Ambient temperature | 0° to +40°C |
| Ambient humidity | 80 RH% or lower (without dew condensation) |
| Ambient conditions | Indoors (not exposed to direct sunlight), free of corrosive/flammable gases, oil mist, and dust. |

■ Removing the button battery insulating sheet

While removing the insulation sheet from the button battery, turn on the electricity.

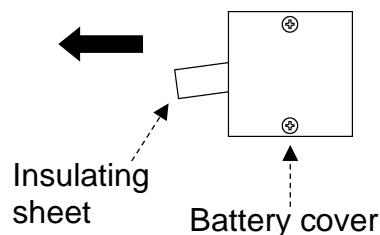
1. Take out the primary filter, secondary filter and the tertiary filters.  [5.1 Replacing Filters Page17](#)
2. Pull out the insulating sheet off the battery cover unit.







| | | |
|--|---|---|
|  CAUTION |  | <ul style="list-style-type: none"> • It will cause a huge consumption of the battery, if the insulation sheet is removed while the device is turned off. |
|--|---|---|

| | |
|-------------|--|
| Note | <ul style="list-style-type: none"> • The button battery drains when the main power switch is OFF. ≤ 1 μA when main power is ON; 40 to 50 μA when main power is OFF • The battery life (2 years, typical) depends on the usage. Take it as a guide value. |
|-------------|--|

3.1.2 Wiring and Piping

■ Wiring

| | |
|--|---|
|  WARNING |  <ul style="list-style-type: none"> • Perform wiring firmly, without bending or pulling cables with excessive force. Fire or electric shock may result. • Ensure that the power supply conforms to the specifications of the device. |
| |  <ul style="list-style-type: none"> • Be sure to connect the ground wire. |
|  CAUTION |  <ul style="list-style-type: none"> • Avoid multiple connections as they can cause voltage reduction. At reduced voltage, the device may fail to operate normally, resulting in failure. |

The device is powered by a single-phase supply.
The tolerance of the supply voltage is $\pm 10\%$.

1. Connect the device attachment plug of the power cord to the power connector on the device.
2. Connect the power supply end of the power cord to the power outlet.

■ Piping

1. Turn the removable flange clockwise until it is secured on the suction port.
2. Connect the suction tube (to be prepared separately) to the removable flange.

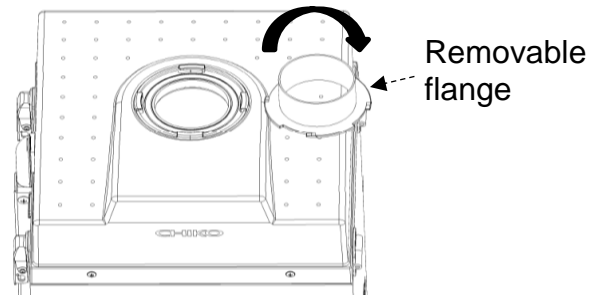

IMPORTANT

- Ensure appropriate piping during operation. The piping should be as short as practicable, with the piping port diameter not too small.

3.2 Operation

1. Turn on the main power switch.
The display indicates the **program version** and the **ID for RS485 communication**.
2. Press the **ON** button on the AT3 panel.
The device starts operation.
3. Check that abnormal noise is not generated and the suction is appropriate.
4. Set a desired suction power level by pressing the **Left/Right arrow buttons**.
The suction power is indicated by the suction power level lamps (1 to 7).

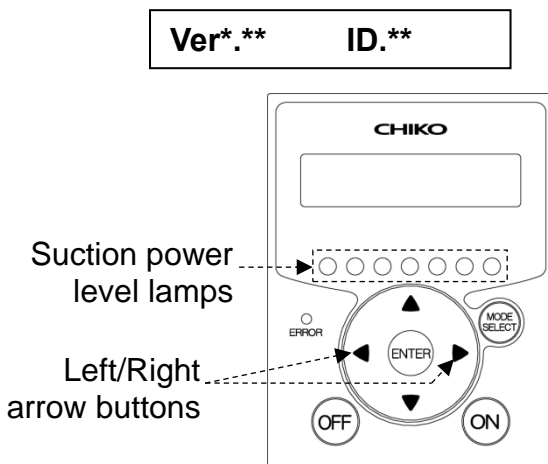

IMPORTANT

- Leave an interval of three minutes or more between on/off switching. Repeated on/off switching at intervals of less than three minutes, in particular less than 30 seconds, may cause failure.

3.3 Registering Initial Pressures

Air volume reduction due to filter clogging is judged based on a registered initial differential pressure and indicated as low air volume (WARN4). Register initial pressures through these steps:

1. Perform the wiring and piping of the device.
2. Start the device at a desired suction power level.
3. Press and hold down the **ENTER** button for three seconds.
The display shows “**Initial DP Get Y**”, prompting confirmation to register/update initial pressures.
4. To proceed with registration/update, press the **ENTER** button.
The device starts to acquire initial pressure.
If you do not want update, press the **MODE SELECT** button to return to normal operation.
5. The device runs through a sequence of suction power levels 1 to 7, to automatically acquire the differential pressure for each level.
While the device is acquiring initial pressures, the display alternates between the “**Initial DP Check**” message and the “suction power level and differential pressure” values.
6. When the registration completes, the display shows the “**Initial DP Entry**” message and the device returns to normal operation.

IMPORTANT

- Ensure that the filters are new.
- Update registered initial pressures once again if piping is changed or all filters are replaced (except for the exhaust filter) after registration of initial pressures.
- If initial pressures are not registered, an “**initial pressure unregistered**” warning (**WARN6**) appears.
- The registered initial pressures can be cleared by holding down the **OFF** button for three seconds when the device is in stop state.

● Clearing registered initial pressures

1. Hold down the **OFF** button for three seconds when the device is in stop state.
The display shows “**Initial DP Clr Y**”, prompting confirmation to clear registered initial pressures.
2. To clear them, press the **ENTER** button.
If you do not want to clear them, press the **MODE SELECT** button to return to normal operation.
3. When the clearing completes, the display shows the “**Initial DP Clr**” message and the device returns to the stop state.

Chapter 4 Configuring Settings (MODE SELECT Mode)

4.1 Screen Transitions in MODE SELECT Mode

To move to the MODE SELECT mode, press the **MODE SELECT** button during stoppage. The **Up/Down arrow buttons** cycle through parameters.

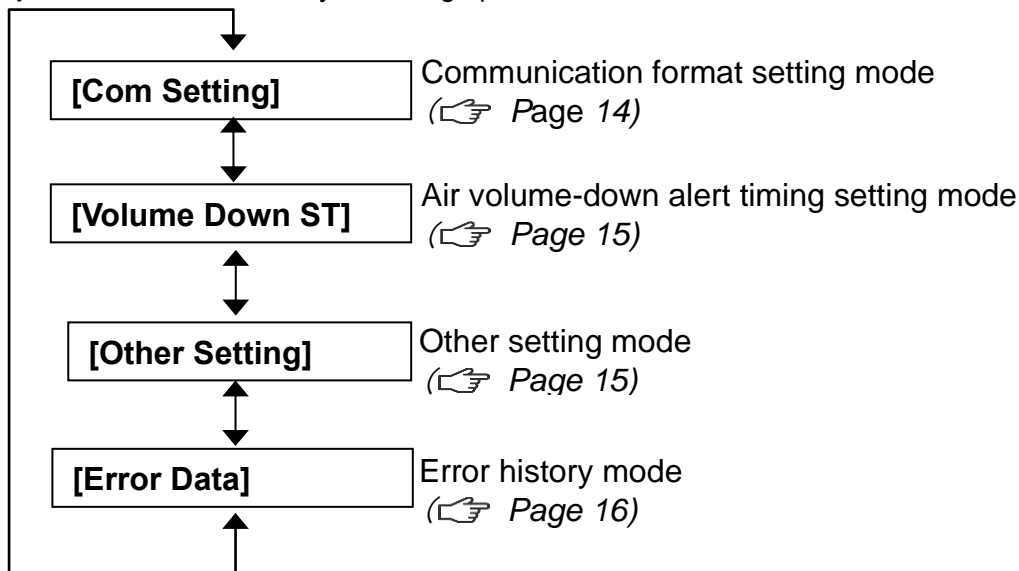

4.2 Communication Format Setting Mode (When Equipped with Communication Function)

This mode sets the below listed items of serial communication format. The settings are enabled after the main power switch is turned off and back on.

| Item | Setting | Default |
|------------------------------|---|-------------------------------------|
| Communication station number | 1 to 25 | 1 |
| Baud rate | 9600 bps, 19200 bps, 38400 bps, 57600 bps, 115200 bps | 9600 bps |
| Bit length and parity | Bit length = 8 bits, with no parity Bit length = 8 bits, odd parity Bit length = 8 bits, even parity Bit length = 9 bits, with no parity | Bit length = 8 bits, with no parity |
| Stop bit | Stop bit = 1 bit Stop bit = 2 bits | Stop bit = 1 bit |

1. Move to the **MODE SELECT** mode.
2. Press the **Up/Down arrow buttons** to move to the communication format setting mode ("**Com Setting**").
3. Press the **ENTER** button.
The communication station number check screen appears, showing the current settings.
4. Press the **Up/ Down** arrow buttons to move to the item you want to set.
5. Press the **ENTER** button.
The setting screen appears.
6. Press the **Up/Down** arrow buttons to select the desired setting.

7. Press the **ENTER** button to determine the setting.
8. To exit this mode, press the **MODE SELECT** button to return to normal mode.

4.3 Air Volume-Down Alert Timing Setting Mode

This mode allows for changing the timing for displaying an **air volume-down warning (WARN4)** as desired.

1. Move to the **MODE SELECT** mode.
2. Press the **Up/Down** arrow buttons to move to the air volume-down alert timing setting mode ("**Volume Down ST**").
3. Press the **ENTER** button.
The current setting appears.
The default is 50%, displayed as "3: Down to 50%".
4. Press the **Up/Down** arrow buttons to select a timing between 30 to 70%.
A lower setting causes the air volume-down alert to occur later, and vice versa.

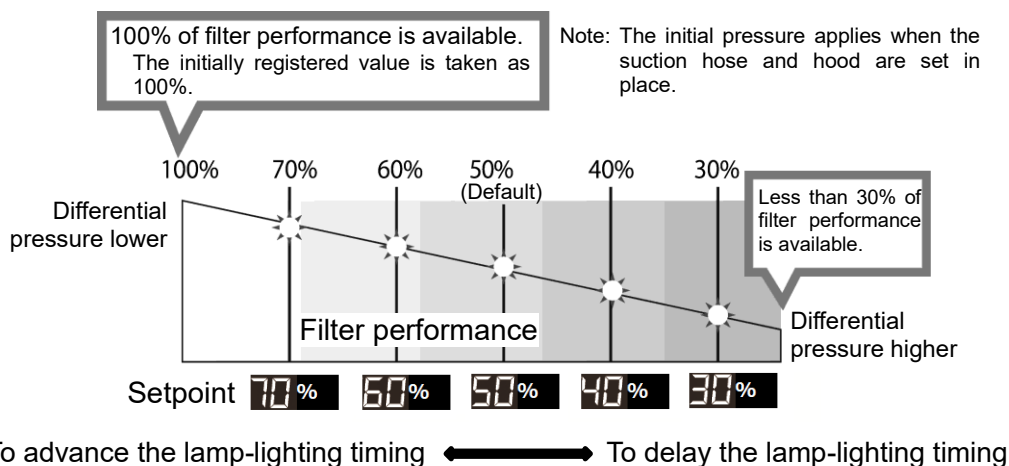

5. Press the **ENTER** button to determine the setting.
6. To exit this mode, press the **MODE SELECT** button to return to normal mode.

4.4 Other Setting Mode

The parameters listed below can be set.

- Date/time setting
☞ "4.4.1 Clock Calibration Mode" (page 15)
- Accumulated run time resetting
☞ "4.4.2 Accumulated Run Time Reset Mode" (page 16)
- Setpoint resetting
☞ 4.4.3 Setpoint Reset Mode" (page 16)

4.4.1 Clock Calibration Mode

This mode sets date and time.

1. Move to the **MODE SELECT** mode.
2. Press the **Up/Down** arrow buttons to move to the other setting mode ("**Other Setting**").
3. Press the **ENTER** button.
The screen displays "**TimeAdjust**".
4. Press the **ENTER** button.

The date setting screen appears.

5. Press the **Up/Down** arrow buttons to change the value.
6. Press the **ENTER** button to determine the value.
Set the value in this order: year, month, and day.
7. After the date is set, the time setting screen appears.
8. Press the **Up/Down** arrow buttons to change the value.
9. Press the **ENTER** button to determine the value.
Set the value in this order: hours, minutes, and seconds.
10. To exit this mode, press the **MODE SELECT** button to return to normal mode.

4.4.2 Accumulated Run Time Reset Mode

This mode resets the accumulated run time (“Runtime”).

1. Move to the **MODE SELECT** mode.
2. Press the **Up/Down** arrow buttons to move to the other setting mode (“**Other Setting**”).
3. Press the **ENTER** button.
The screen displays “**TimeAdjust**”.
4. Press the **Up/Down** arrow buttons to change the display to “[Runtime Reset]”.
5. Press the **ENTER** button.
The display shows “**Reset Runtime Y**”, prompting confirmation to reset the accumulated run time.
To reset, press the **ENTER** button.
6. To exit this mode, press the **MODE SELECT** button to return to normal mode.

4.4.3 Setpoint Reset Mode

This mode allows for restoring the defaults for communication format, air volume-down alert timing, and resetting the accumulated run time.

1. Move to the **MODE SELECT** mode.
2. Press the **Up/Down** arrow buttons to move to the other setting mode (“**Other Setting**”).
3. Press the **ENTER** button.
The screen displays “**TimeAdjust**”.
4. Press the **Up/Down** arrow buttons to change the display to “[Setting Reset]”.
5. Press the **ENTER** button.
The display shows “**1:YES**”, prompting confirmation to reset setpoints.
To reset, press the **ENTER** button.
6. The display shows “**1:START**” for reconfirmation.
7. Press the **ENTER** button to reset the setpoints and move the device to normal mode.

4.5 Error History Mode

The error history allows for checking four occurrences of errors.

The error history is cleared by turning off the main power switch.

1. Move to the **MODE SELECT** mode.
2. Press the **Up/Down** arrow buttons to move to the error history mode (“**Error Data**”).
3. Press the **ENTER** button.
The display indicates the number of the most recent error that has occurred and the accumulated run time at that occurrence.
4. Press the **Down arrow button** to display the history of four errors in order from the latest.
5. To exit this mode, press the **MODE SELECT** button to return to normal mode.

Chapter 5 Maintenance and Checkup

CAUTION



- Before starting maintenance and checkup, be sure to break the electrical circuit by turning off the power supply and disconnecting the plug from the power outlet.

5.1 Replacing Filters

If clogging occurs, a “WARN2” warning appears. Replace the primary filter.

If “WARN2” remains displayed after replacing the primary filter, replace the tertiary filter.

5.1.1 Replacing the Primary filter

IMPORTANT

- The filter`s should be replaced in an area large enough to open the suction-side filter case.

1. Remove the locks (2 places) on the intake side filter case and open the filter case.

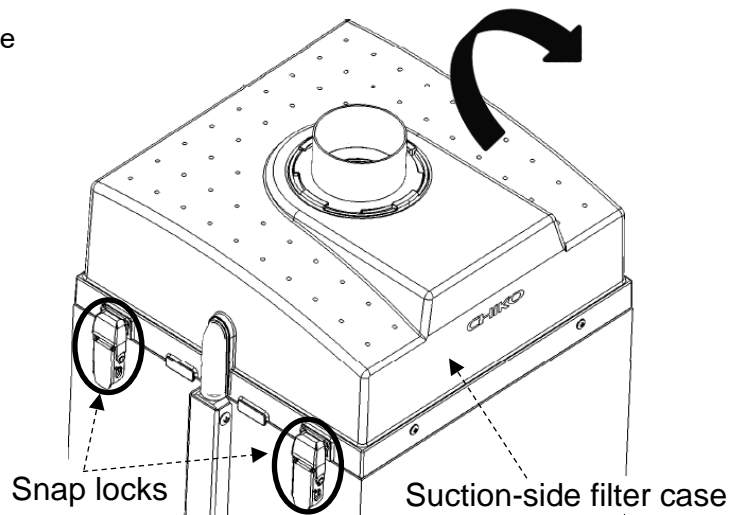

2. Remove the collision plate and replace the primary filter.

Collision plate

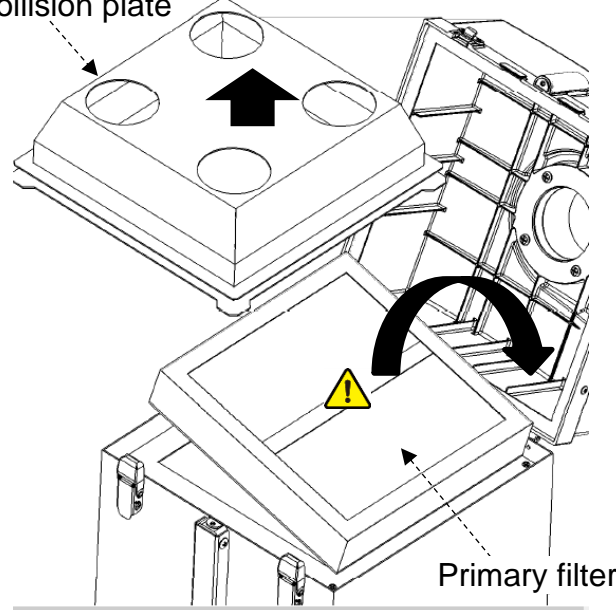

CAUTION



When installing the filter, attach the packing downward.

5.1.2 Replacing the secondary filter

☞ 5.1.1 「Replacing the Primary filter」
(Page 17)

3. Grasp the handle and replace the activated carbon box.

* The new activated carbon box does not come with a handle.
Please reuse the handle.

| | |
|---|---|
|  CAUTION |  |
| Please use the handle correctly referring to the photo. Incorrect use may damage the dust collector. | |

Storage

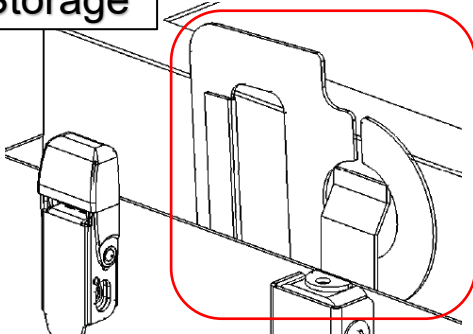

Maintenance

 The handle is reused.

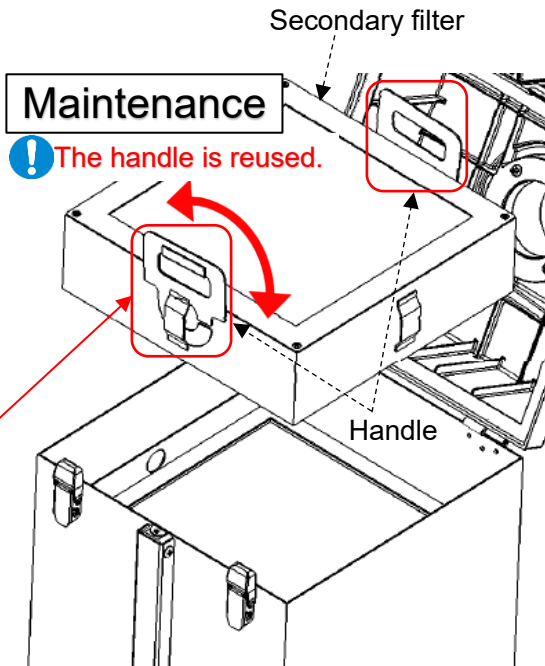

5.1.3 Replacing the tertiary filter

☞ 5.1.1 「Replacing the Primary filter」(Page 17)

☞ 5.1.1 「Replacing the secondary filter」(Page 18)

4. Remove the third filter frame.
* Hook it and take

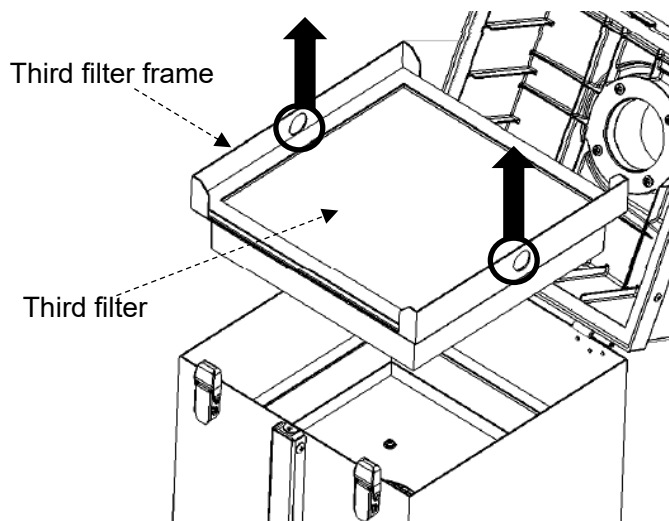

5. Replace the third filter.

| |
|--|
|  CAUTION |
| When installing the filter, attach the packing upward. |

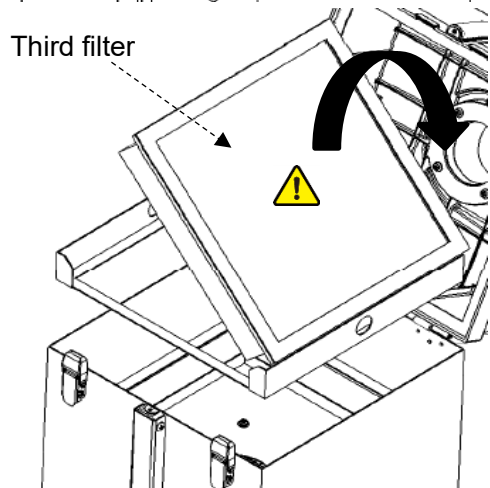

5.2 Replacing Fuse



Replace the fuse if any of them is blown by an overcurrent due to trouble with internal equipment. The fuse is contained in the black box beside the power switch. The replacing fuse should be designated by **CHIKO AIRTEC**.

Designated fuse: 218 Series from Littell fuse [250V 5A]

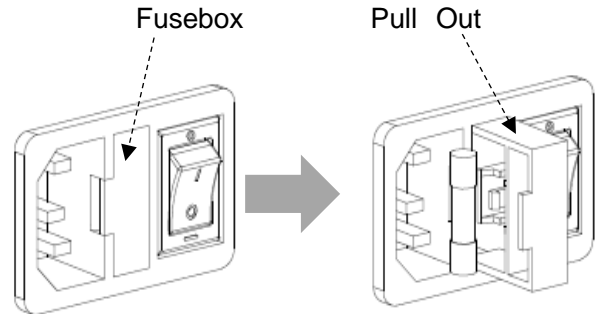
1. Take out the black box beside the power switch.
If it cannot be taken out smoothly, please use a flathead screwdriver or other thin-tipped tool to take it out carefully.
2. Remove the fuses out of the fuse box and replace with new ones.



5.3 Replacing the Button Battery

| | | |
|--|---|---|
|  CAUTION |  | <ul style="list-style-type: none"> The button battery case used in the device is for CR2477 size. Do not use button batteries other than CR2477. Turn on the electricity of the device while replacing the battery, or it will cause a huge consumption of the battery. |
|--|---|---|

1. Turn on the electricity of the device.
 2. Open the suction-side filter case on the intake side and remove the primary/secondary and the tertiary filters.
-  *5.1 Replacing Filters Page 17*
3. Remove the battery cover by extracting its two screws.

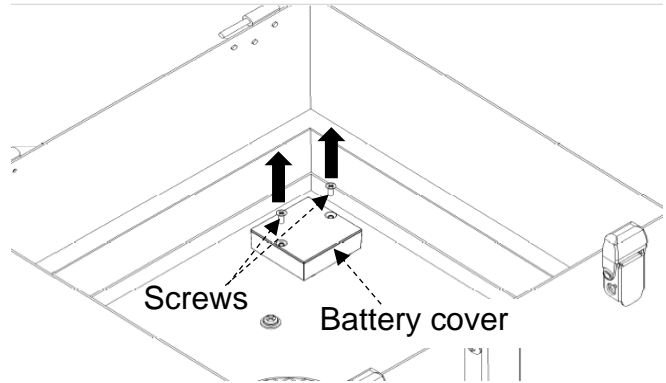

4. Push the claw rightward and remove the button battery.
5. Replace with a new button battery.
6. Install the battery cover back in place.
7. Cut off the electricity of the device.

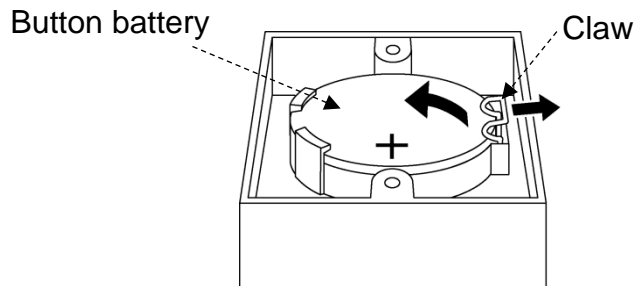

5.4 Daily Checkup

| Check item | Frequency | Check that: |
|---------------------------|------------------|------------------------------------|
| Filter case | Before operation | Filter case is completely closed. |
| Suction port | Before operation | Suction port is not blocked. |
| Exhaust condition | Daily | Exhaust port is not blocked. |
| Operation panel condition | Daily | Error or warning is not displayed. |

5.5 Errors/Warnings

If an error/warning occurs, the self-diagnosis function built-in the device lights (flashes) the **ERROR** lamp and shows display data and error number alternately on the display.

For a description of errors/warnings displayed, see “5.5.2 Error/Warning Table” (page 22).

For faults and conditions not covered by self-diagnosis, see “5.6 Troubleshooting” (page 23).

5.5.1 Action on Errors/Warnings



If the self-diagnosis function of this device has detected an error or warning, take the steps below to clear the error or warning.

The screenshots for illustration are provided as examples.

- If an error/warning occurs, the **ERROR** lamp lights (flashes) and the display shows display data and error number alternately. If there are two or more error/warning occurrences, the one with the highest priority is displayed.

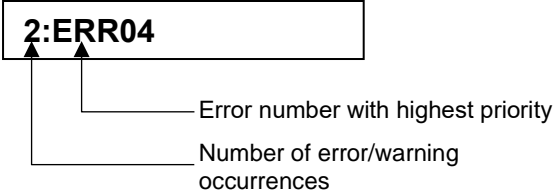
- Press the **MODE SELECT** button to move to the error history mode. If there are two or more error/warning occurrences, the number of occurrences precedes the error number.

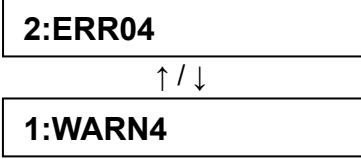
- If there are two or more error/warning occurrences, press the **Up/Down arrow buttons** to check the error numbers.

- Take an action appropriate for the error number shown on the display.
 “5.5.2 Error/Warning Table” (page 22)
- Press the **MODE SELECT** button to move to the error clear mode.

- To clear the error/warning, press the **ENTER** button to return to normal mode. To leave the error/warning uncleared, press the **MODE SELECT** button to return to normal mode.

If an error/warning is left uncleared:

- For an error/warning that continues the operation....All buttons remain enabled.
- For an error/warning that stops the operation.....The ON button is disabled.

To resume the operation, clear the error/warning.

IMPORTANT

- Once **WARN6** or **WARN7** is cleared, it will not reappear until the main power switch is turned off and back on.

5.5.2 Error/Warning Table

| Priority | Error No. | Error/warning | Description | ERROR lamp | Device operation | Action |
|---|-----------|---------------------------------------|--|------------|---------------------|--|
| High  ↓ Low | ERR03 | Rotational frequency error | Motor rotational frequency declining (or stopping) | Flashing | Remains operational | Follow the remedies for ② in “5.6 Troubleshooting” (👉 Page 23). |
| | ERR04 | Internal temperature error | Temperature around the blower is too high. | Lit | Stop | Follow the remedies for ② in “5.6 Troubleshooting” (👉 Page 23). |
| | ERR06 | Pressure error | Operation continued at low pressure for more than preset period. | Lit | Stop | Follow the remedies for ② in “5.6 Troubleshooting” (👉 Page 23). |
| | ERR07 | F-RAM write error | Cannot write to F-RAM. | Flashing | Remains operational | Contact CHIKO AIRTEC. |
| | ERR08 | Communication error | BCC judgment mismatch | Flashing | Remains operational | Contact CHIKO AIRTEC. |
| | WARN1 | Internal temperature high | Temperature around the blower is close to the error threshold. | Flashing | Remains operational | Follow the remedies for ② in “5.6 Troubleshooting” (👉 Page 23). |
| | WARN2 | Filter replacement time limit expired | Operation continued at low air volume for more than preset period. | Flashing | Remains operational | Follow the remedies for ③ in “5.6 Troubleshooting” (👉 Page 23). |
| | WARN3 | Inadequate pressure (suction) | Suction pressure is low. | Flashing | Remains operational | Follow the remedies for ② in “5.6 Troubleshooting” (👉 Page 23). |
| | WARN4 | Inadequate air volume | Air volume is reduced by filter clogging. | Flashing | Remains operational | Follow the remedies for ③ in “5.6 Troubleshooting” (👉 Page 23). |
| | WARN5 | Exhaust pressure error | Exhaust pressure is too high. | Flashing | Remains operational | Follow the remedies for ③ or ④ in “5.6 Troubleshooting” (👉 Page 23). |
| | WARN6 | Initial pressure unregistered | Initial pressure is not registered yet. | Flashing | Remains operational | Register initial pressures. (👉 Page 13) |
| | WARN7 | Battery voltage low | Remaining battery level is low. | Flashing | Remains operational | Replace the button battery. (👉 Page 20) |

5.6 Troubleshooting

| No. | Trouble phenomenon | Cause | Remedy |
|-----|---|---|---|
| ① | Organic EL display shows nothing. | Power not turned on. | Turn on the power. |
| | | Blown fuse | Replace the fuses. ☞ "5.2 Replacing Fuse" (page 19) |
| ② | Motor fails to start or suddenly stops running. | Faulty motor | Call for repair. The motor must be replaced. |
| | | Stopped due to overload or abnormal temperature | [1] Check that the exhaust/suction ports are not blocked. The ERROR lamp lights up if completely blocked. [2] Check the rated voltage. [3] Check for multiple (octopus) connections. [4] Check for motor overheat due to either filter clogging or suction temperature. After the checks [1] to [4], take corrective action, and then turn the main power switch off and back on. If the operation cannot resume, the temperature thermostat of the motor may be active. Turn off the main power, and after 30 minutes, resume the operation. |
| | | Primary or secondary filter not in place | Install the primary and secondary and the tertiary filters correctly. |
| | | Disengaged snap locks | Engage the snap locks case securely. |
| ③ | Lower suction force | Clogged filter | Replace filters. ☞ "5.1 Replacing Filters" (page 17) If filters are left clogged, the device may result in "untrapped particles" or "temperature rise in dust collector". |
| | | Clogged piping or suction port | Check if piping is clogged or the suction port blocked. |
| | | Faulty motor | Call for repair. The motor must be replaced. |
| ④ | Untrapped particles | Improper filter installation | Reinstall filters. ☞ "5.1 Replacing Filters" (page 17) |
| | | Filter broken or past service life | Replace filters. ☞ "5.1 Replacing Filters" (page 17) |
| | | Clogged filter | Replace filters. ☞ "5.1 Replacing Filters" (page 17) |
| ⑤ | Odd noise or vibration from motor | Foreign matter entered in blower. | Call for repair. |
| | | Broken motor bearing | Call for repair. |

Note: For other phenomena, contact CHIKO AIRTEC.

Chapter 6 Useful Utilization (Optional)

6.1 Remote Cable

6.1.1 Electrical Diagram

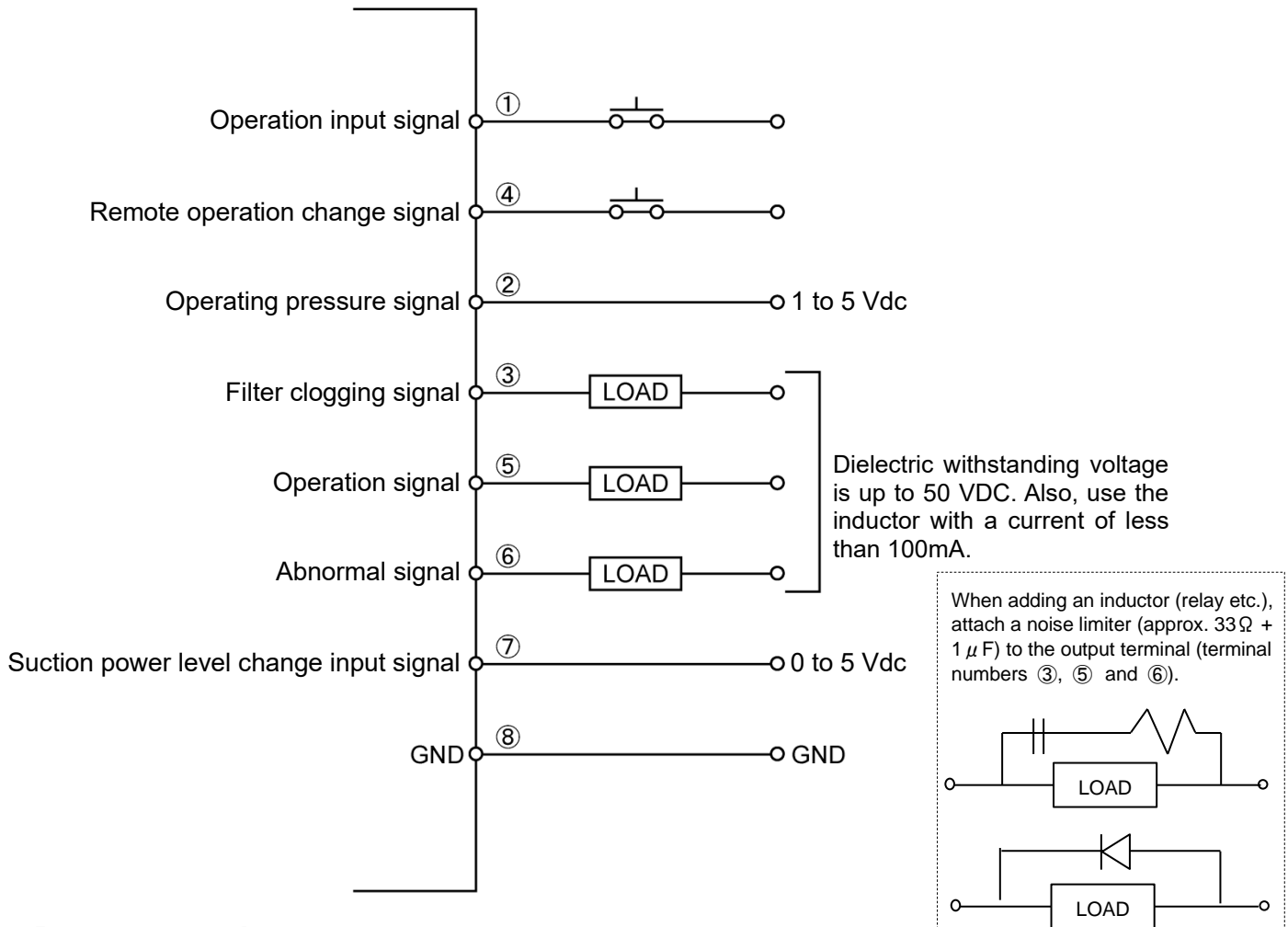

■ Remote operation

- Pin ④When turned on, control switches to the **remote mode**, enabling remote operation while disabling ordinary operation via the AT3 panel.
- Pin ②Outputs an analog pressure signal.
- Pins ③, ⑤, and ⑥ ...In case of adding an inductor (e.g., relay), install a noise limiter (approx. $33\ \Omega + 0.1\ \mu\text{F}$), diode, or the like.

■ Connection examples

● Pins ① and ④ (input)

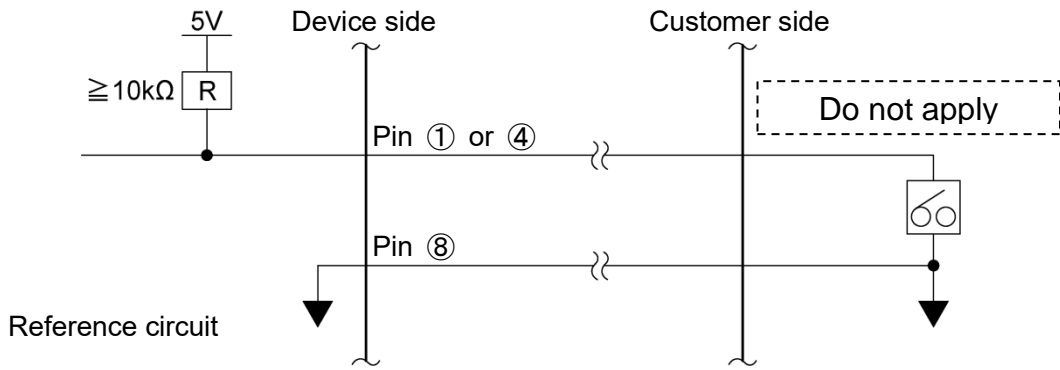

● Pin ② (analog output)

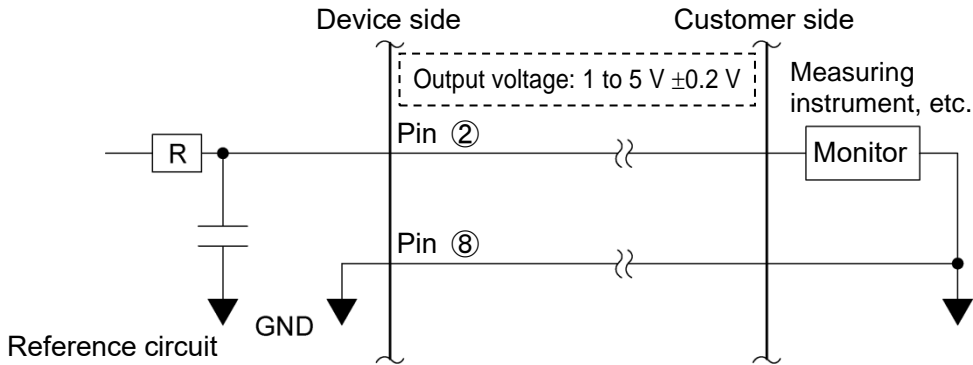

● Pins ③, ⑤, and ⑥ (open collector output)

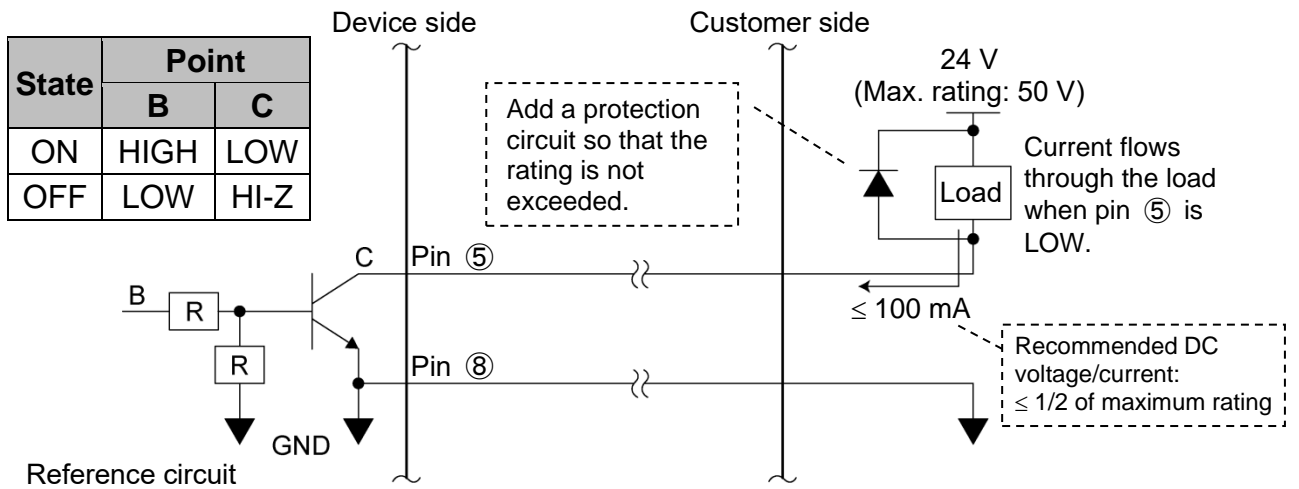

● Pin ⑦ (input)

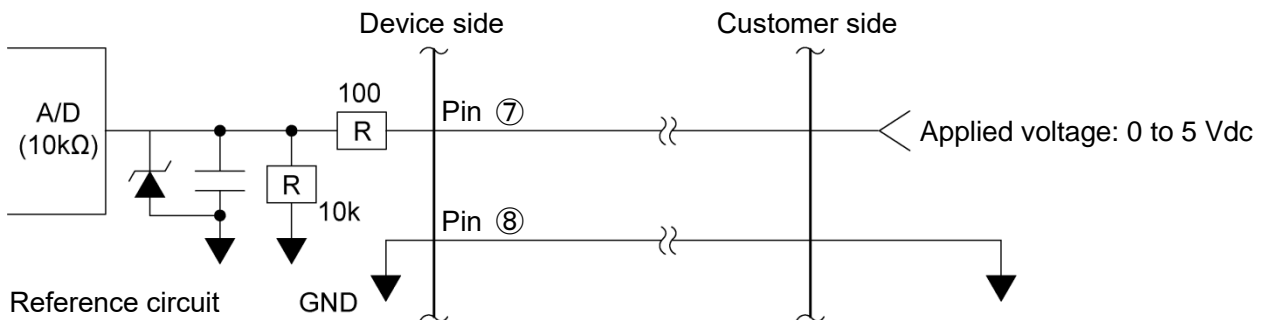

6.1.2 Pin Assignments

| Wire color | Pin # | Signal name | Description | |
|--------------|-------|----------------------------------|------------------------|--|
| Black | ① | Operation input signal*1 | Remote signals (Input) | With ④ and ⑧ short-circuited, ① is short-circuited to start operation. |
| Red/white | ④ | Remote operation change signal*1 | | ④ and ⑧ are short-circuited to start remote operation. Once this short circuit is established, ordinary operation via the touch panel is disabled. |
| Yellow | ⑦ | Suction power level change*2 | | Voltage (0 to 5 V) can be applied between ⑦ and ⑧ to change suction power levels. |
| Yellow/white | ⑧ | GND | | — |
| Black/white | ② | Operating pressure signal | Output signals | Outputs the current operating pressure. Analog signal: 1 to 5 V; impedance ≥ 4.7 kΩ |
| Red | ③ | Filter clogging output signal*3 | | Outputs a clogging signal. Open collector output: NPN |
| Green | ⑤ | Operation output signal*3 | | Outputs an operation signal (ON lamp). Open collector output: NPN |
| Green/white | ⑥ | Abnormal signal*3 | | Outputs an abnormal signal. Open collector output: NPN |

【Filter clogging signal】 : When WARN2, WARN4 or WARN5 occurred

【Abnormality signal】 : When any ERR occurred

*1: Contact input (non-voltage contact)

*2: Analog input (0 to 5 V)
Do not apply more than +5.0 V.

*3: Open collector output
The maximum absolute rating is 50 V for voltage and 100 mA for current.

The recommended value is half or less of the rating.

【Threshold table for voltage applied to pin ⑦】

| Suction power level | Voltage (Vdc) |
|---------------------|---------------|
| 1 | 0.6 to 1.1 |
| 2 | 1.2 to 1.7 |
| 3 | 1.8 to 2.3 |
| 4 | 2.4 to 2.9 |
| 5 | 3.0 to 3.5 |
| 6 | 3.6 to 4.1 |
| 7 | 4.2 to 5.0 |

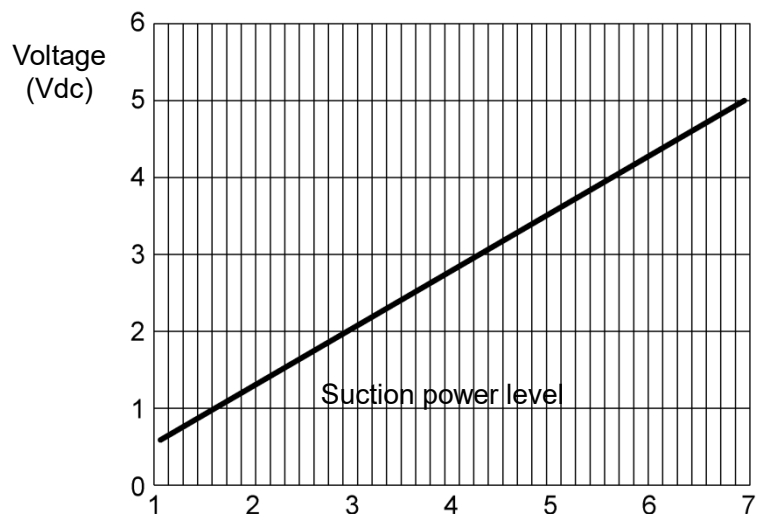

Allow for an error of ±4% when setting voltage. Specifically, apply the midpoint of the voltage range for each level.

6.1.3 Remote Operation

- For on/off switching via remote operation, short-circuit pins ④ and ⑧.
Pin ① is short-circuited → ON
Pin ① is not short-circuited → OFF
☞ “6.1.2 Pin Assignments” (page 26).
- Do not short-circuit between pins ④ and ⑧ when taking signals by on/off switching on the device side.
Take out desired output signals as per the description in “6.1.2 Pin Assignments”.
- Initial pressure registration, ON/OFF operation and suction power levels cannot be operated or changed on the device side during transition to remote operation.
- The current suction power level is stored in memory. This means that the previously effective level is stored even if main power is turned off.

6.2 Communication Function

By using optional communication board set (model: **RS-485** or **RS-EN**), you can retrieve information such as operation “ON/OFF” and filter clogging.

6.2.1 RS485 Communication

See “4.2 Communication Format Setting Mode

(When Equipped with Communication Function)” for instructions on configuring communication settings.

☞ “4.2 Communication Format Setting Mode

(When Equipped with Communication Function)” (page 14)

6.2.2 Ethernet

For details, refer to the instruction manual of the Ethernet device you purchased separately.

6.3 Removable Flange

Flanges can be replaced without using tools if a different diameter of suction port is required to suit particular operating environments.

Replaceable flange diameters

| Model | Flange diameter (mm) | | | |
|----------------|----------------------|----------------|----------------|------|
| | φ 38 | φ 50 | φ 65 | φ 75 |
| CKU-060AT3-ACC | FRJ-D-38-35-92 | FRJ-D-50-35-92 | FRJ-D-65-35-92 | — |

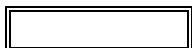

: The removable flanges shown enclosed in double lines are included in standard shipment.

Chapter 7 Appendix

7.1 Specifications

| Model | Motor rated output | Voltage | Current value | Frequency | Max. suction volume | Max. suction static pressure | Noise value* ¹ | Mass |
|-------------------|--------------------|-------------------------------------|---------------|-----------|------------------------|------------------------------|---------------------------|--------|
| CKU-060AT3-ACC | 50W | 100 V* ² single phase | 2.3 A | 50/60Hz | 2.8m ³ /min | 2.5kPa | 53 to 61 dB | 15.8kg |
| CKU-060AT3-ACC-T | | 200 V single phase | 1.5 A | | | | | |
| CKU-060AT3-ACC-CE | | 220 to 230 V single phase | 1.4 A | | | | | |

*1: Noise value is measured with a hose connected to the suction port, at a distance of 1 m from the device, on the A scale dB.

*2 Can be used in the area of 100-115V.

7.2 Consumables List

| Part name | Replacement intervals* ¹ | CKU-060AT3-ACC (-T,-CE) |
|------------------|-------------------------------------|-------------------------|
| Primary filter | 1 to 3 months | CHF-2222-40 |
| Secondary filter | 3 to 6 months | ACC-2525-75ST |
| Tertiary filter | 6 to 12 months | CHF-2525-50 |

*1: The replacement intervals vary with the use frequency, environment, and suction concentration (substance and composition) at the customer's site.

7.3 Electrical Diagram

7.3.1 CKU-060AT3-ACC

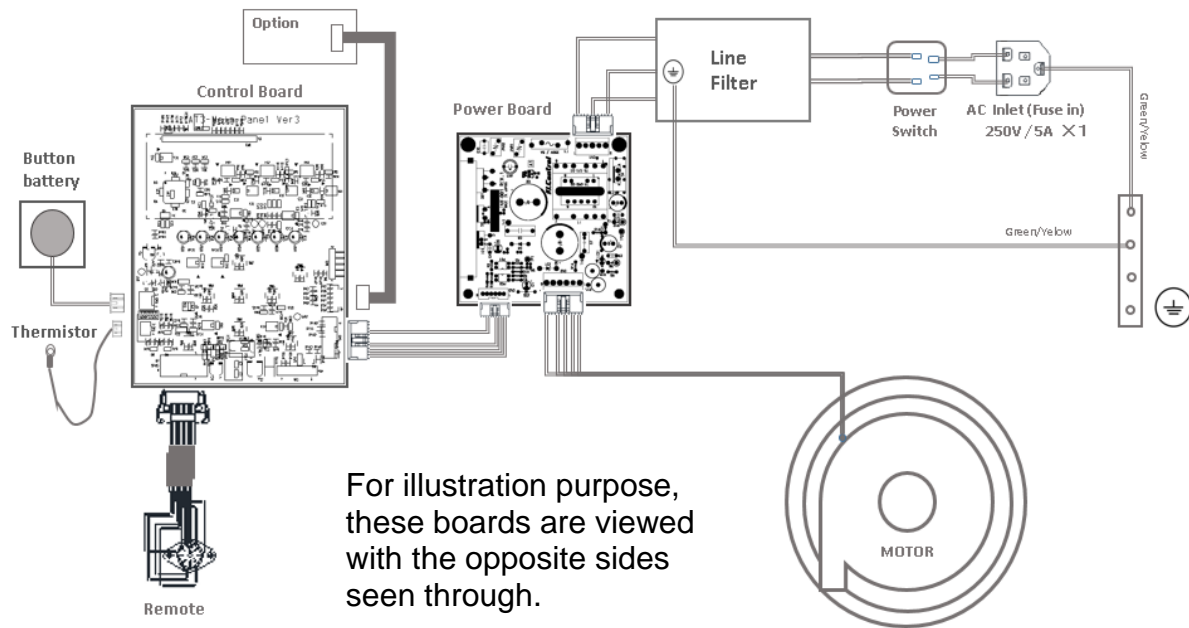

■ Scope of Warranty and Responsibility

● Warranty period

We will repair free of charge any failures or damages that may occur during normal operating conditions within 12 months of shipment.

However, this does not apply to the consumables listed in "7.2 Consumables List".

☞ "7.2 Consumables List" (page 28)

The following cases will be handled as a charged service even within the warranty period.

- Failure or damage caused by violation of the instructions in this document.
- Failure or damage due to use in an operating environment other than that described in this document.
- Repair, alteration, disassembly, or similar action done any party other than CHIKO AIRTEC or a CHIKO AIRTEC-designated sales agent.
- Blemish, contamination, or other appearance change that may occur during use.
- Replacement of any consumable or accessory, or use of any part not designated by CHIKO AIRTEC.
- Failure of damage due to falling after purchase or accident during transport.
- Failure or damage due to natural disasters, such as: fire, salt damage, gaseous damage, earthquake, wind and flood damage, lightning strike, and abnormal voltage.

● Repairs

Travel expenses for on-site service will be chargeable whether within or outside the warranty period.

For repair reasons, improved parts may be used for repair.

CHIKO AIRTEC will not be liable for any damage resulting from use of this device, such as damage caused by failure of the device or by erasure of data.

■ Memo about purchase

| | | |
|------------------|---------------------------|-----------------------|
| Model | | Serial No. |
| Date of purchase | | Operation start date: |
| Your name | | |
| Address | Phone Person in charge | |

販売元/Distributor



※支店・営業所・製造拠点の最新情報は、弊社ホームページよりご確認下さい。
For the latest information on our branches, sales offices, and factories, please visit our website.
<https://www.showadenki.co.jp>

製造元/Manufacturer

チコーエアーテック株式会社
CHIKO AIRTEC CO.,LTD.
〒562-0012 大阪府箕面市白島 2-27-24
2-27-24,Hakushima, Minoh, Osaka 562-0012, Japan
TEL (81) 072-720-5151 FAX (81) 072-720-5133
URL <http://chiko-airtec.jp/>