



Comprehensive Catalog of Environmental Equipment



Moving in new ways.
— MAGOKORO Company —



Proposals for Creating a Pleasant Workplace Environment



NC lathes



Grinders



Machining Centers open type



Machining Centers

Mistrésa

For collecting mist generated by machine tools



Parts washers

Page 2-6

Grindrésa

Mist & Dust Collector for Grinding / Polishing Machines

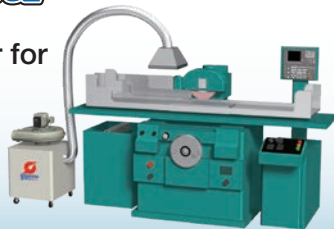

Page 5

Dustrésa

For collecting dust generated by production equipment



Page 7-8

Workrésa

Working table with Dust collectors



Hand tools processing



Page 9

Fumeresa

Compact Welding Fume Collector

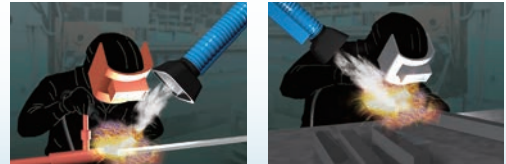

Page 10

Fumeresa

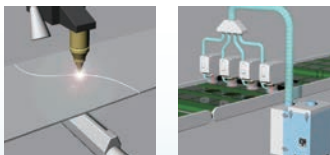

For collecting smells and fumes of laser markers

Page 9

Windracer

For distributing stable air flow long distances and even temperatures

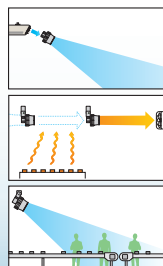

Page 10

WINDBAG™

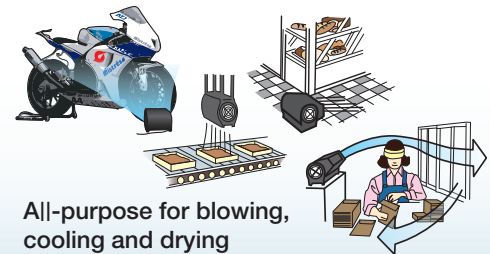

All-purpose for blowing, cooling and drying

Page 10

Ventiresa

Push-pull type ventilation system

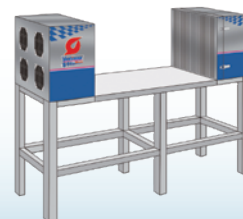

Page 10

Mistrésa Selecting Method

Choose according to your purpose

[Motor output from 0.2 kw to 2.2 kw]
 [Two types of Front filters and 3 types of End filters]
 [Both Horizontal and vertical mounting]
 In total you can choose between 60 combinations.

Front demister	Front filter	Taper cone	End demister	End filter
<p>Corresponds to water-soluble mist. Maintenance easy. Dust is not suitable. Doesn't trap dust. Low amounts of mist</p> <p>water-soluble mist low</p> <p>Maintenance easy</p>	<p>Corresponds to mist containing dust (chip fragments), washable, needs to be replaced when clogged</p> <p>all mist abundant</p> <p>dust abundant</p> <p>Maintenance necessary</p>	<p>Mist particles collide on the taper cone. Coming together on larger droplets falling down by their own weight</p> <p>water-soluble mist low</p> <p>Maintenance free</p>	<p>It corresponds to water-soluble mist, maintenance is easy, dust unsuitable, less mist</p> <p>water-soluble mist low</p> <p>Maintenance easy</p>	<p>Corresponds to mist containing dust (chip fragments), needs to be replaced when clogged</p> <p>all mist abundant</p> <p>Maintenance necessary</p>

Choose the right model for your application

With motor output ranging from 0.2 kW to 2.2 kW, two filter box parts, and three mist collector parts, there are over 60 combinations (including both horizontally and vertically installed models) to choose from.

CRM - H04 - S11

①
② ③ ④

- ① Output (H02, H04, H07 H15, H22)
- ② Horizontal (S) or vertical (V) installation
- ③ Demister (1) or filter (2)
- ④ Taper cone (1), demister (2), or filter (3)

		Back	Mist collector side		
			1	2	3
Filter box side	1	Front demister	Taper cone	End demister	End filter
	2	Front filter	Type 21	Type 22	Type 23

Choose by working chamber volume

If the mist source is covered

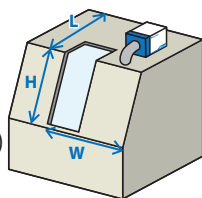

Working chamber volume (m³) = W × L × H
 Airflow volume (m³/min) = Working chamber volume × test coefficient*1

W: Working chamber width (m)
 L: Working chamber length (m)
 H: Working chamber height (m)

*1 Test coefficient

- If door is open at least 15 sec. after work is complete: 4
- If door is open at least 10 sec. after work is complete: 6
- If door is open in less than 10 sec. after work is complete: 8

Contact us for more information if the mist source is exposed.



NC lathe



Grinder



Specification

Model CRM-H□□-S□□	Output (kW)	Power Supply	Frequency (Hz) Current (A)	50Hz		60Hz		Collection efficiency (%)	Max. intake temperature (°C)	Noise (dB (A)) 50/60Hz	Approx. weight (kg)
				Max. volume (m ³ /min)	Max. static pressure (kPa)	Max. volume (m ³ /min)	Max. static pressure (kPa)				
CRM-H02	0.2		50/60/60 1.6/1.3/1.3	4.1	0.55	4.8	0.75	98.4	50	64/67	26
				5.4		6.2		99.2			
				4.6		5.4		99.6			
				3.8		4.5		98.9			
				5.1		5.8		99.5			
4.3	5.1	99.8									
CRM-H04	0.4	* Three Phase	50/60/60 2.0/2.0/2.0	4.4	0.75	5.2	1.10	98.4	50	68/72	32
				6.0		7.0		99.2			
				4.9		5.9		99.6			
				4.1		4.9		98.9			
				5.5		6.8		99.5			
4.6	5.6	99.8									
CRM-H07	0.75	* Three Phase	50/60/60 3.0/3.3/3.3	8.4	1.10	9.8	1.60	98.4	50	73/78	42
				9.8		11.5		99.2			
				8.0		9.6		99.6			
				7.8		9.4		98.9			
				9.2		10.5		99.5			
7.6	9.2	99.8									
CRM-H15	1.5	* Three Phase	50/60/60 6.9/7.0/7.0	15	1.60	18	2.25	98.4	50	81/83	67
				18		21.5		99.2			
				15		18		99.6			
				14.5		17.5		98.9			
				17		20		99.5			
14.5	17.5	99.8									
CRM-H22	2.2	* Three Phase	50/60/60 10.2/10.4/10.4	18	1.70	21.5	2.40	98.4	50	83/86	77
				24.5		28.5		99.2			
				18.5		22.5		99.6			
				17.5		20.5		98.9			
				22.5		27		99.5			
18	21	99.8									

* Can change to another voltage; up to 480 V 50/60 Hz

Outline drawing

CRM-H02-S□□
CRM-H04-S□□

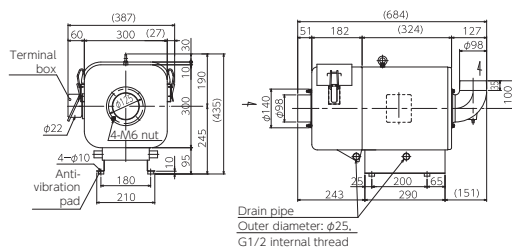

CRM-H07-S□□

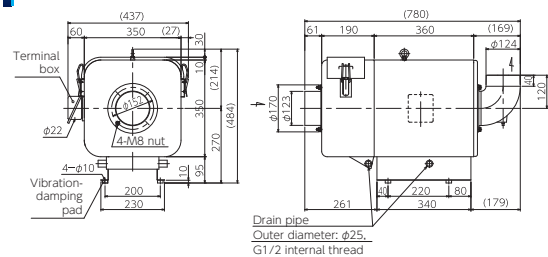

CRM-H15-S□□

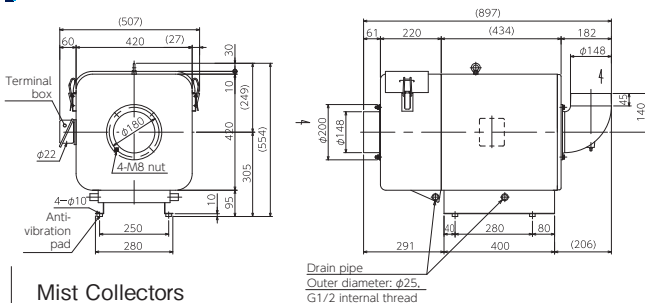

CRM-H22-S□□

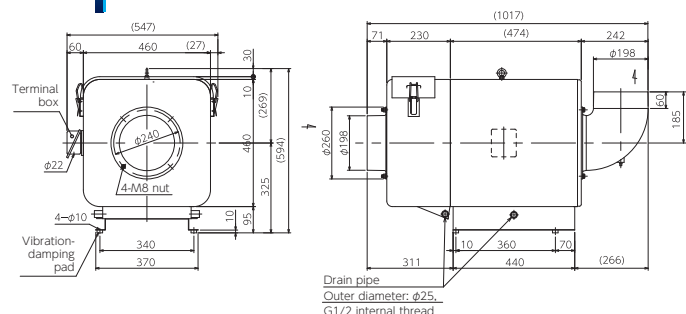



NC lathe



Specification

Model CRM-H □□ -V□□	Output (kW)	Power Supply	Frequency (Hz) Current (A)	50Hz		60Hz		Collection efficiency (%)	Max. intake temperature (°C)	Noise (dB (A)) 50/60Hz	Approx. weight (kg)	
				Max. volume (m ³ /min)	Max. static pressure (kPa)	Max. volume (m ³ /min)	Max. static pressure (kPa)					
CRM-H02	0.2		50/60/60 1.6/1.3/1.3	3.7	0.55	4.4	0.75	98.7	50	63/66	27	
				V11		4.5		5.3				99.2
				V12		3.9		4.6				99.7
				V13		3.4		4.0				98.8
				V21		4.1		4.8				99.4
				V22		3.5		4.2				99.7
CRM-H04	0.4		50/60/60 2.0/2.0/2.0	4.0	0.70	4.7	1.00	98.7	50	71/75	34	
				V11		5.0		5.9				99.2
				V12		4.4		5.2				99.7
				V13		3.8		4.4				98.8
				V21		4.6		5.5				99.4
				V22		4.1		4.9				99.7
CRM-H07	0.75	* Three Phase 50Hz : 200V 60Hz : 200V/ 220V	50/60/60 3.0/3.3/3.3	7.4	1.00	8.6	1.45	98.7	50	77/81	43	
				V11		9.0		10.5				99.2
				V12		7.6		9.0				99.7
				V13		6.8		8.2				98.8
				V21		8.4		10				99.4
				V22		7.0		8.4				99.7
CRM-H15	1.5		50/60/60 6.9/7.0/7.0	14	1.50	17	2.15	98.7	50	78/83	69	
				V11		16		19				99.2
				V12		14		17				99.7
				V13		13.5		15.5				98.8
				V21		15		18				99.4
				V22		13.5		15.5				99.7
CRM-H22	2.2		50/60/60 10.2/10.4/10.4	19.5	1.60	22.5	2.30	98.7	50	81/85	78	
				V11		22		26				99.2
				V12		19		22.5				99.7
				V13		18		21				98.8
				V21		21		24.5				99.4
				V22		17.5		21				99.7

* Can change to another voltage; up to 480 V 50/60 Hz

Outline drawing

CRM-H02-V□□
CRM-H04-V□□

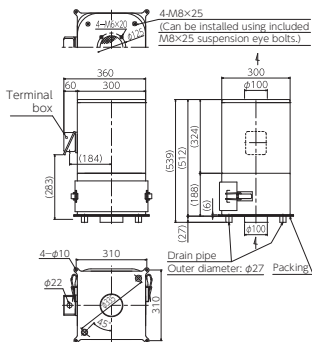

CRM-H07-V□□

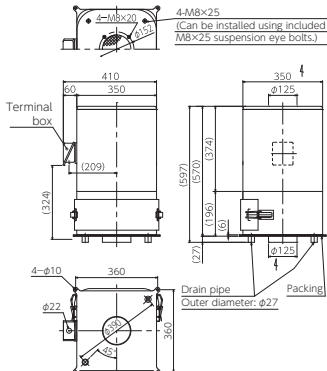

CRM-H15-V□□

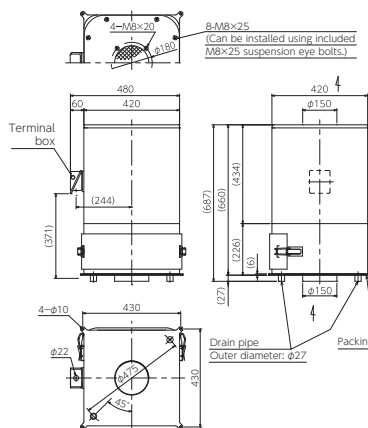

CRM-H22-V□□

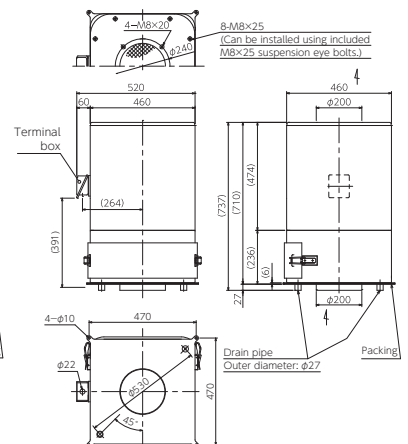

Horizontal

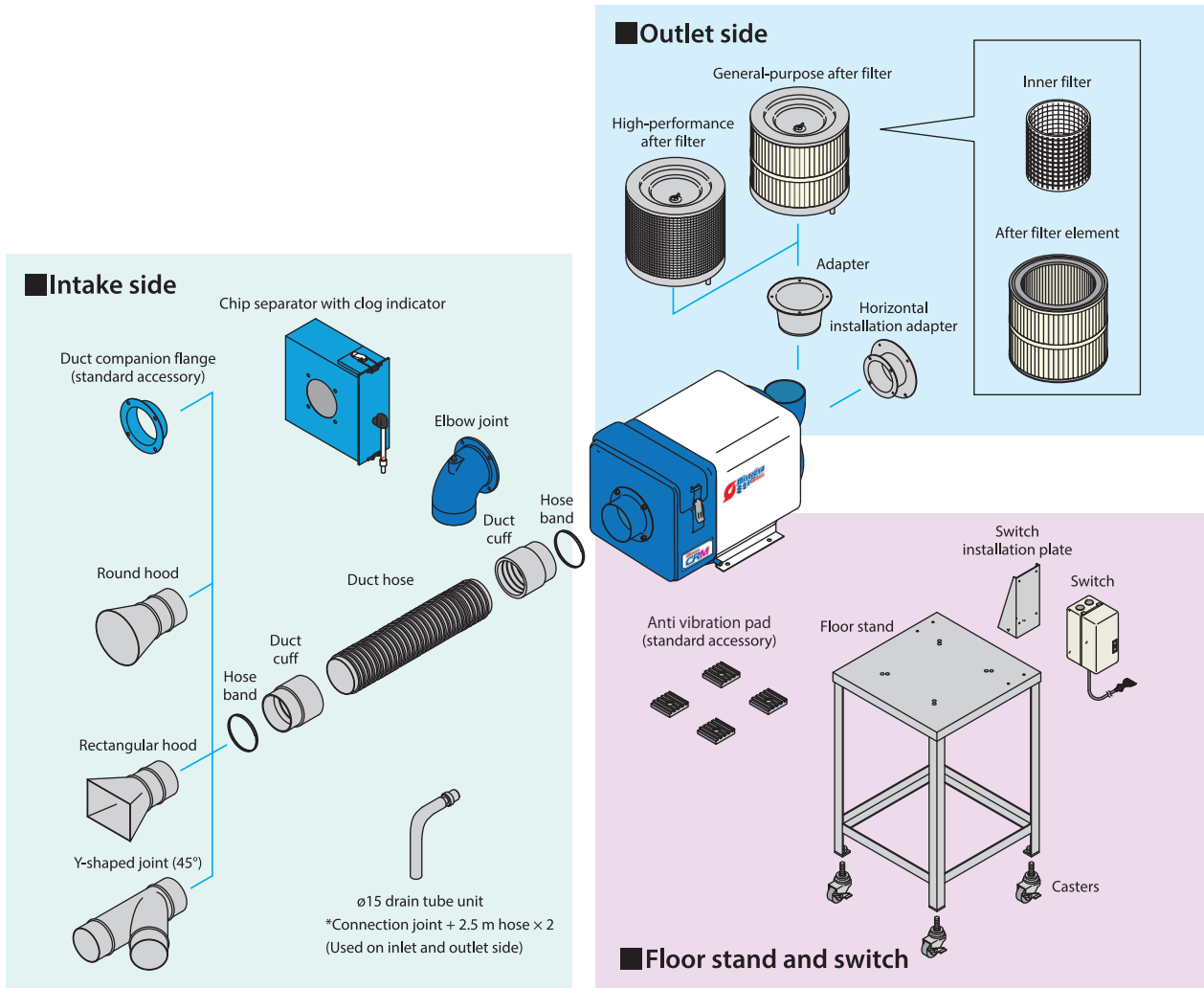

Vertical

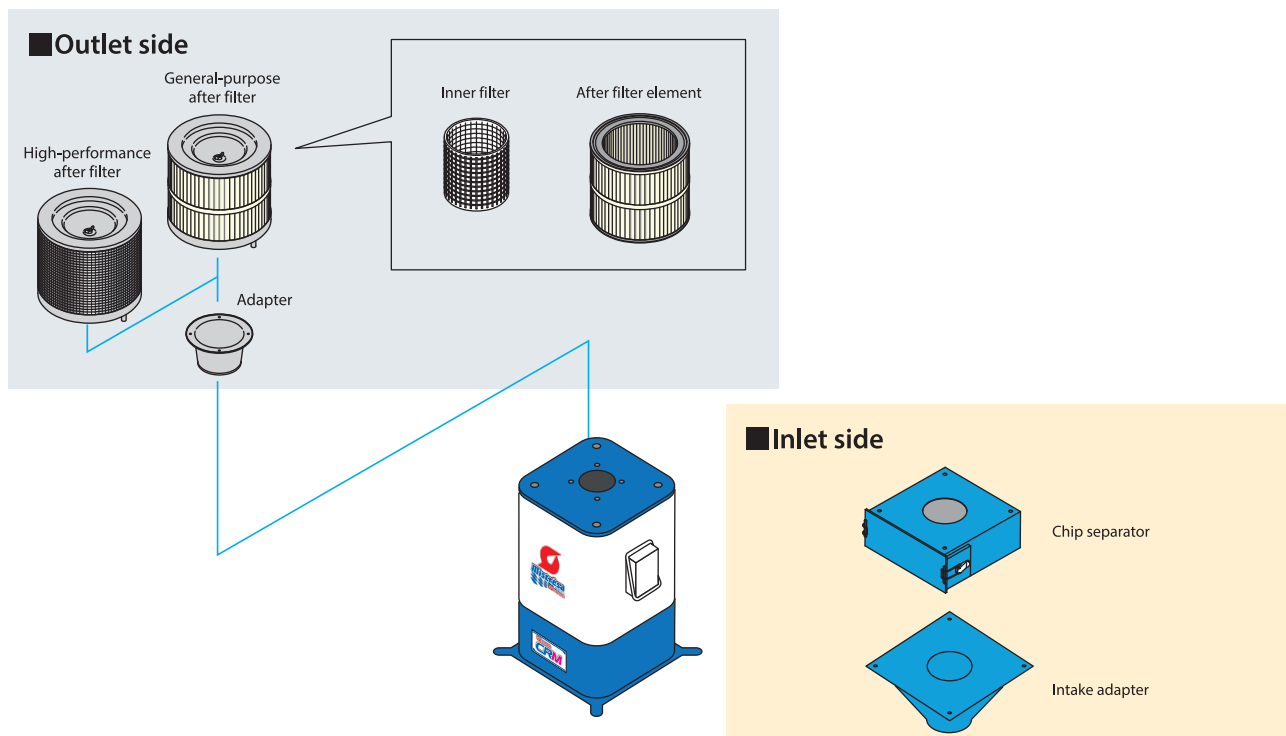

Dustresa CFA Compact-type



CFA-110



CFA-H215C/T
CFA-H220



CFA-H240



CFA-H410, CFA-H515

Crusher



Semiconductor manufacturing equipment



Specification

Model	Motor (kW-P)	*2 Power Supply	*1 Volume (m ³ /min)	*1 Static pressure 50/60Hz (kPa)	Filtration area (m ²)	Dust collection box capacity (ℓ)	Noise Front:1m dB(A)*1 Front:1.5m dB(A)*2	Approx.weight (kg)
CFA-110	0.2-2	100V, single phase	4	0.8/1.18	0.8	3.1	64*1	25
CFA-H215C	0.4-2	100V, single phase	5	1.76	1.5	6.9	64*1	47 (50Hz) 44 (60Hz)
CFA-H215T	0.4-2	200V, three phase	5	1.86	1.5	6.9	64*1	49 (50Hz) 47 (60Hz)
CFA-H220	0.75-2	200V, three phase	8	2.15	2	6.9	65*1	59
CFA-H240	1.5-2	200V, three phase	16	2.45	4	16.9	68*1	135
CFA-H410	2.2-2	200V, three phase	30	2.45	10.6	45	64*1	197
CFA-H515	3.7-2	200V, three phase	40	2.45	14.1	68	67*1	238

*1 The values of volume and static pressure indicate a standard specification point.

*2 Can change to another voltage
single phase; up to 240 V 50/60 Hz
three phase; up to 480 V 50/60 Hz

Model	dimensions (mm)							
	A	B	C	D	E	F	G	H
CFA-H215	486	446	745	75	100	216	-	-
CFA-H220	486	446	745	97	100	211	-	-
CFA-H410	786	680	1462	198	205	740	42	780
CFA-H515	876	750	1612	225	220	750	42	870

Outline drawing

CFA-110

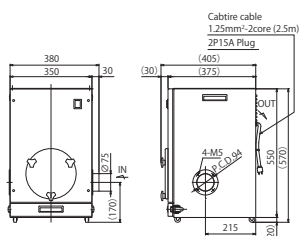

CFA-H215C/T
CFA-H220

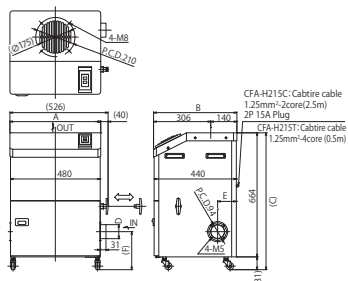

CFA-H240

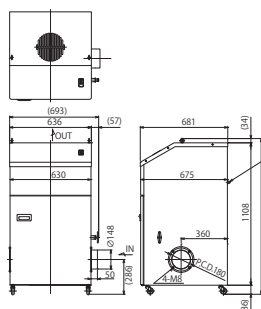

CFA-H410
CFA-H515

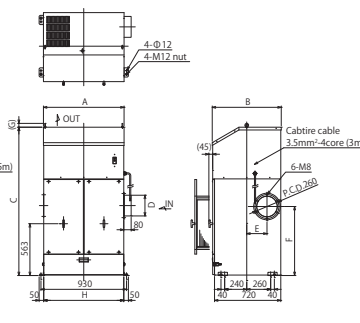

Attached to the machine



Specification

Model	Motor (kW-P)	* Power Supply	Volume (m ³ /min)	Static pressure 50/60Hz (kPa)	Filtration area (m ²)	Required air supply (ℓ/min)	Dust collection box capacity (ℓ)	Noise Front:1m dB(A)*1 Front:1.5m dB(A)*2	Approx, weight (kg)
CFM-H10	1.5-2	200V, three phase	20	2.06	10.4	40	29	62	180
CFM-H20	2.2-2	200V, three phase	30	2.45	15.6	50	42	68	222
CFM-H30	3.7-2	200V, three phase	40	2.45	23.4	60	32×2	68	286
CFM-H40	5.5-2	200V, three phase	60	2.65	31.2	80	65×2	71	408

* Can change to another voltage; up to 480 V 50/60 Hz

Outline drawing

Model	dimensions (mm)											
	A	B	C	D	E	F	G	H	I	J	K	L
CFM-H10	650	720	1415	150	105	500	42	710	210	230	200	180
CFM-H20	870	720	1410	200	130	500	42	930	210	255	225	230
CFM-H30	870	1000	1495	225	145	500	42	930	250	280	250	-

CFM-H10 CFM-H20 CFM-H30

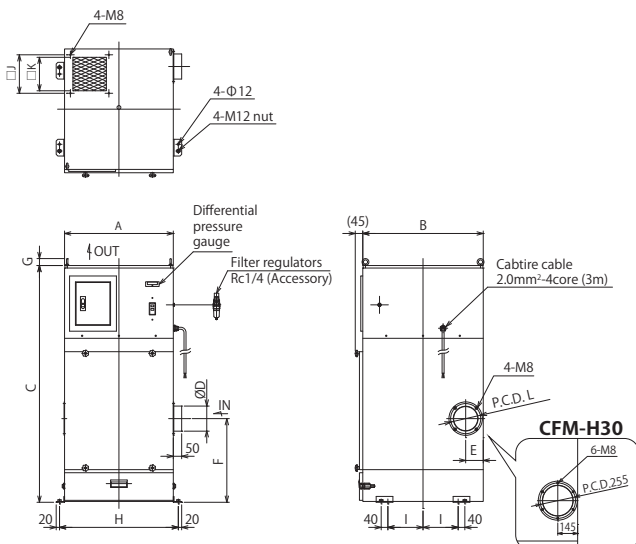

CFM-H40

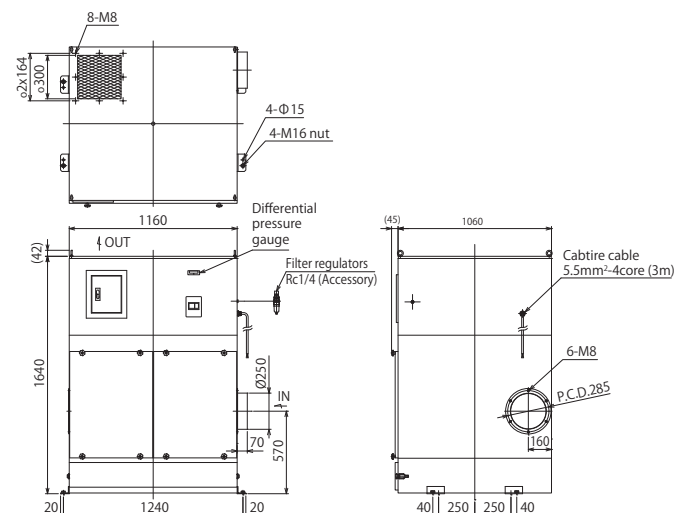



Installation example

AIR BLOW, HAND TOOL, Polishing process, and others



Specification

	Model	Motor (kW-P)	Power Supply	Frequency (Hz)	Volume (m ³ /min)	Wind velocity (m/s)	Filtration area (m ²)	Dust collection box capacity (L)	Noise Front 1.0 m dB (A)	Approx. Weight (kg)
Vertical	WRM-H04S	0.4-2	100V- Single Phase	50/60	5.0	1.2	1.5	6.9	65 (reference value)	65/63
Desk	WRM-H04S-D		100V- Single Phase		7.5	4.4(*1)			68.5(*1)	Desk part: 66 Dust collector part: 31

※Please contact us for more information on special specifications such as: foot switch, 3 phase, different plug type, explosion proof, etc.
*1 The values written on the specifications refer to those of the medium size opening.

Outline drawing

Compact vertical type

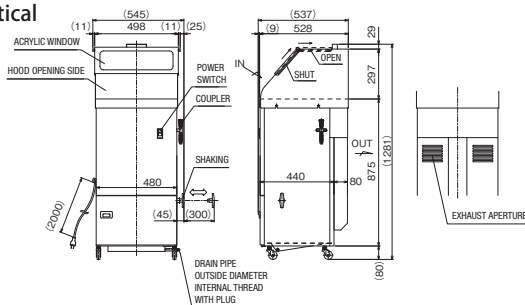

Working area type

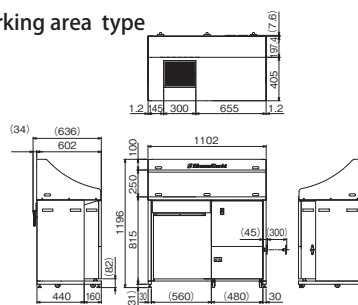

Specification

	Single tank	Double tank
Fumeresa model	FRM-H15	FRM-H37
Suction velocity	11m/s	17m/s
Motor	1.5kW 2P	3.7kW 2P
Voltage	200V or 380V	200V or 380V
Frequency	50Hz or 60Hz	50Hz or 60Hz
Filter	Cotton cartridge filter (1 piece)	Cotton cartridge filter (2 pieces)
Weight	Approx. 80 kg	Approx. 210 kg

Welding work



Fumeresa Collect Fume and smells



Installation example



Collecting fumes generated during laser cutting.



Collecting fumes generated during laser cutting lithium-ion batteries.

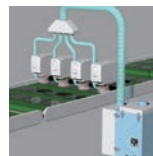

Collecting fumes generated during the marking of liquid crystal substrate.

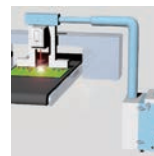

Collecting fumes generated during the marking light guide plates.



Specification

Model	Out Put (kW)	* Power Supply	Frequency (Hz)	Max Volume (m ³ /min)	Max Static Pressure(kPa)	Noise (dB(A)) 50/60Hz	Approx Weight (kg)
CBA-1000AT3-HC-DSA-V1	0.5	100V, Single Phase	50/60	3.2	9.5	54~59	32.5
CBA-1000AT3-HC-DSA-V1-CE	0.5	220~230V, Single Phase	50/60	3.2	9.5	54~59	32.5
CKU-060AT3-ACC	0.05	100V, Single Phase	50/60	2.8	2.5	53~61	15.8
CKU-060AT3-ACC-CE	0.05	220~230V, Single Phase	50/60	2.8	2.5	53~61	15.8

- Use the product for collecting dry, non-explosive dust.
- Do not use the product in places where flammable, explosive or corrosive mist, smoke or gas is accumulated or located nearby.



**WR-100W
WR-200W**



Improving air conditioning and heating efficiency

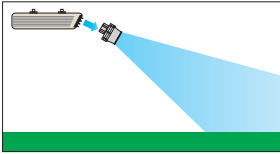

Inducing movement of hot air / steam

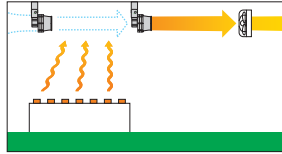

Supply air locally

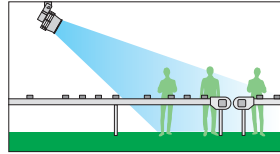

Purposes

1. Improves efficiency of air-conditioning equipment
2. Guides heat and steam
3. Locally supplies air

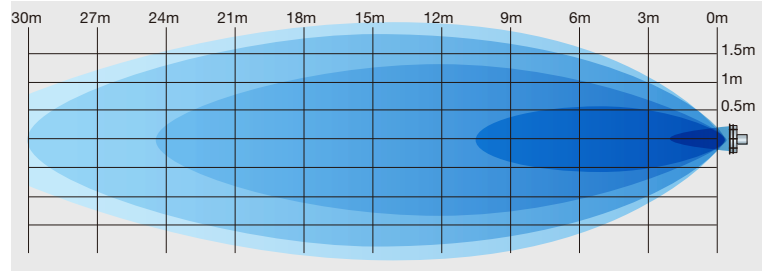

Specification

Model	Phase	Output (kW)	*Frequency (Hz)	*Voltage (V)	Rated current (A)	Noise (dB (A))	Blowing angle (°)	Weight (kg)
WR-100W	Single Phase	0.1	50	220	1.0	56	35	15
WR-200W		0.2		with plug	2.2	66		17

* Can change to another voltage; up to 240 V 50/60 Hz

WINDBAG™

WB-02



Features

1. Powerful wind source
2. Adjustable discharge angle
3. Robust
4. Small and lightweight

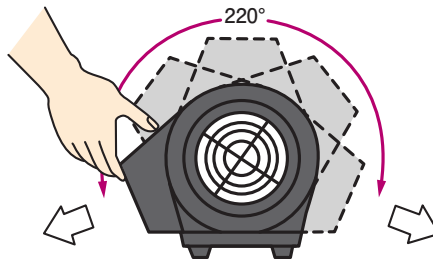

Specification

Model	*Power Supply	Output (kW)	*Frequency (Hz)	Current (A)	Maximum Airflow (m³/min)	Weight (kg)	Cord Length (m)
WB-02T	220V Single Phase	0.2	50	1.0	8.5	10	7

* Can change to another voltage; up to 240 V 50/60 Hz



Push-pull type ventilation system

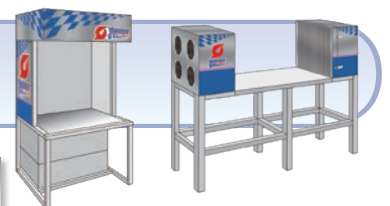

Are you assessing for chemical substance risks?

Showa Denki will assist in all from consultations to installations!!

Please contact us for more details.





Contacts

SHOWA DENKI CO., LTD.

E-mail: web-info@showadenki.co.jp

SHOWA DENKI (KOREA) CO., LTD.

E-mail: skr@showadenki.co.jp

SHOWA DENKI (THAILAND) CO., LTD.

E-mail: sthinquiry@showadenki.co.jp

SHOWA DENKI (TAIWAN) CO., LTD.

E-mail: stw@showadenki.co.jp

<http://www.showadenki.co.jp>

