

# Fume Collector for



## Operation Manual & Cautions



Thank you for purchasing Fumeresa from Showa Denki. This manual explains the specifications for the [Fumeresa FRM-H37].

Please read the operating instruction and cautionary information carefully to ensure that the Fumeresa is used in a **safe and efficient manner**. Special attention should be given to cautionary information which bears [  ] the mark.

**Keep this manual in a secure location where it can be easily accessed**

### [Contents]

1. Safety precautions .....	1
2. Item to check at product delivery .....	1
3. Name of each parts .....	2
4. Specificaton .....	2
5. Precautions .....	3
6. Operation .....	3
7. Maintenance and inspections .....	4-5
8. About disposal .....	5
9. Troubleshooting .....	6
10. Warranty .....	6
11. Contact information .....	6

## 1. Safety precautions

 **Warning** indicates that there is a possibility of [an accident leading to death or serious injury] or [fire occurrence] if mishandled.

 **Caution** indicates things that lead to [accident leading to injury] and [product damage] if mishandled.

### **Warning**

 Careless use of this machine could result in serious injury or accidents.

 This machine is intended to collect welding fumes. Do not use to inhale flammable solvents, oil, cigarettes with fire, etc., as they may cause a fire. Also, do not suction powder material such as plastic, aluminum, magnesium, etc. that may explode.

 This unit is not explosion proof. It can not be used in explosive atmospheres.

 Wear protective equipment such as gloves and dust masks when cleaning this machine or replacing the filter.

### **Caution**

 This unit is dry type. Do not use for inhale fume that contain a large amount of water or oil. It may cause premature clogging of the filter.

 Do not drop, strike or crush filters used in this machine. It may cause dust leakage.

## 2. Item to check at product delivery

Although all our products are thoroughly tested and inspected prior to shipment, nonetheless the customer should check the following items after delivery.

- Verify that the delivered product (model, etc.) is the same with the ordered item.
- Verify that the product has not been damaged or deformed, etc., during shipment.
- Verify is there a missing item to the components of the machine.

Please store the machine as the following environment condition.

- Indoor, please avoid direct sunlight
- Temperature between 0°C~40°C
- Humidity between 10%~90% (No condensation)

When storing or unused for a long time (more than 3 months), it is recommended covering the machine with vinyl or similar in the dry place with little temperature change.

### 3. Name of each parts

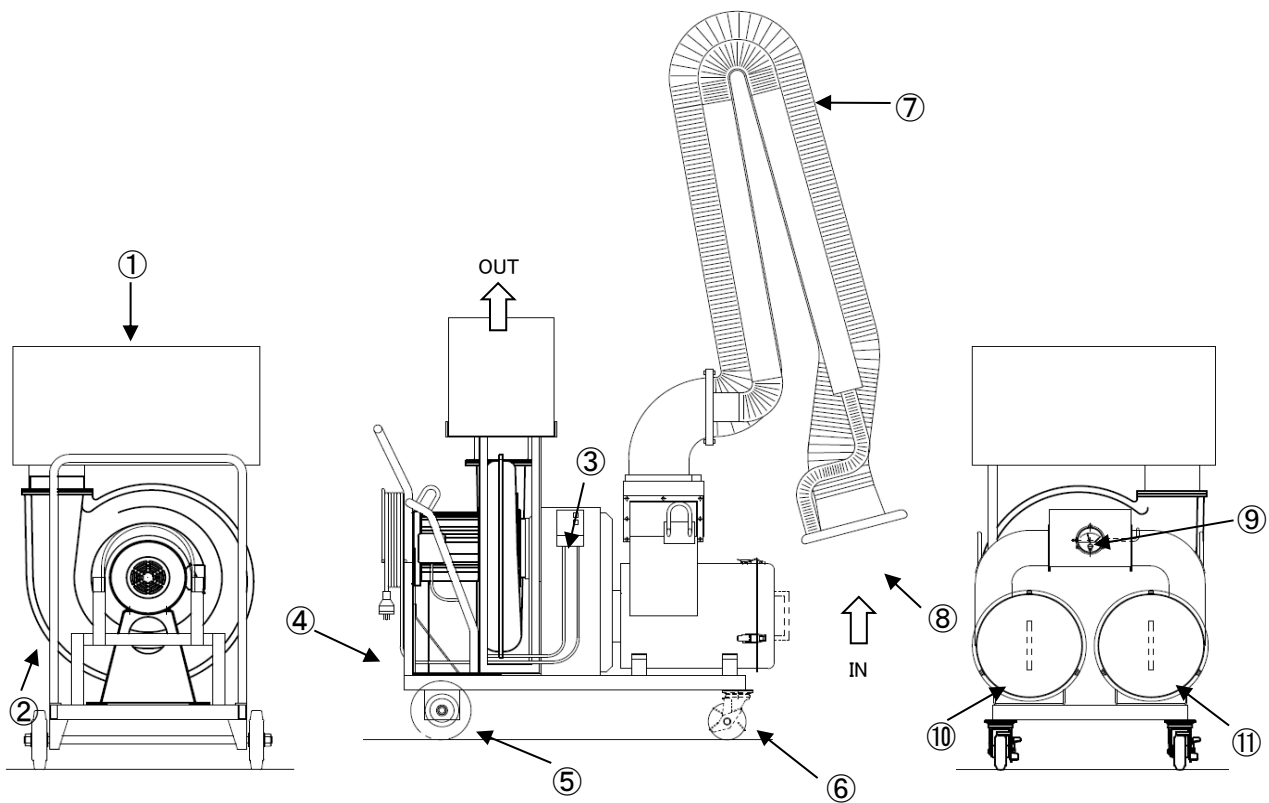

No.	Name	No.	Name
①	Silencer	⑦	Flexible arm
②	Blower	⑧	Hood
③	Switch box (with thermal protector)	⑨	Manometer
④	Plug	⑩	Tank (L)
⑤	Caster rear wheel	⑪	Tank (R)
⑥	Caster front wheel (With stopper)		

### 4. Specifications

Model	FRM-H37	Notes
Suction velocity	17m/s	Hood opening (initial)
Motor	3.7kW 2P	
Voltage	200V or 380V	200V or 380V It is not shared.
Frequency	50Hz or 60Hz	50Hz or 60Hz It is not shared.
Filter	Cotton cartridge filter	2 pieces
Weight	Approx. 210kg	

## 5. Precautions

- (1) Please install indoor horizontal location. Do not get water or oil.
- (2) Do not move while the flexible arm extended
- (3) Please check the manometer value and clean the filter regularly. ※For the cleaning method, please refer to page 4 section [7. Maintenance and inspection (2) Filter cleaning and replacement method]
- (4) The heat resistance temperature of the flexible arm about around 120 °C. If the inhale air exceeding the heat resistance temperature for a long time, the duct will be deformed.  
※ When the duct is deformed, it may form a gap or suction may be decreased.
- (5) If unused for a long time, please unplug from the outlet for safety reason.  
Also, fix the caster (front wheel) with a stopper.  
※ Be sure to fix the left and right (2 places) casters with stoppers.
- (6) If you feel that the machine is abnormal (such as burnt, heated, or high sound), stop operation immediately and unplug.
- (7) This model is divided into 2 types: 50 Hz-only machine and 60 Hz-only machine. Please use the product that match with your frequency.
- (8) Do not modify this machine by yourself. It may cause damage.
- (9) This unit is not explosion proof. It can not be used in explosive atmospheres.
- (10) When moving the machine with an overhead crane etc., remove the silencer and sling it on.

## 6. Operation

### [Preparation]

※ Please check the following items before use.

- (1) Connect the plug into the outlet  
※ If the outlet capacity is less than 20A, the breaker or fuse may break
- (2) Make sure that the manometer guideline (black) points to "0".
- (3) Turn on / off the switch and check that the blower is rotating clockwise (as viewed from the motor side).  
※ The manometer needle will swing even in reverse rotation make sure to check this before use.  
※ Please see page 5 [7. Maintenance Inspection (5) Phase change method of switch box]
- (4) Turn on the "switch" and check that there are no leaks or abnormal noise in any part.

### [Operation]

- (1) Please install this machine in any place. ※ Please fix the caster with stopper.
- (2) Turn on the switch and let it suck welding fumes.
- (3) If you want to move the weld, please set the hood according to the location.  
※ The suction capacity increases as it gets closer to the welding point, but if it is too close, will be inhaling the shielding gas, etc., which may affect the welding strength.  
※ When moving the flexible arm, please operate with the handle on the hood. Pulling any part other than the handle may cause damage.
- (4) Continuous operation is possible, if you follow the procedure above.

### [Stop]

- (1) Please turn off the switch.
- (2) Please store the flexible arm and cable, will not interfere with the passage.

## 7. Maintenance and inspections

### (1) Flexible arm

※ Please read the instruction manual attached separately and use it properly

- 1) Make sure that the suction port of the hood is not blocking by dust or foreign matter.  
It may cause the suction capacity decrease.
- 2) Do not use the duct part that has damage or deterioration.

### (2) Filter cleaning and replacement method

#### 【Cleaning method】

- 1) When the manometer needle (black) reaches the red pointer, it is time to clean the filter.  
※In some cases, even if the filter is clogged, the manometer needle may not reach the red pointer.

① Open the tank cover.

※There is a latch next to the patch lock. Release the lock while pressing the latch.

② Turn the wing nut of the filter section and remove the filter.

③ Insert the jet gun (air gun) from the front (packing side) of the filter.

※Use the gun nozzle with the nozzle facing downward. If it is horizontal or upward, dust will be scattered.

④ Clean in accordance with the filter cleaning direction shown in Fig.1.

⑤ After cleaning the lower surface, rotate the filter and repeat steps ③ to ④

⑥ Cleaning is complete when the filter rotates once.

⑦ Insert the filter after cleaning and tighten the wing nut to fix it.

※If the tightening is weak, fumes will leak from the outlet.

⑧ Attach the tank cover.

※The tank cover is divide into left and right.

※There are "L" and "R" markings on the front of the tank cover.

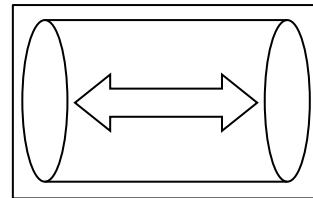

【Fig. 1】Filter cleaning direction

- 2) Clean two filters at the same time.

#### 【Replacement method】

- 1) The filter is cartridge type. The exchange procedure is as follows.

① Open the tank cover.

※There is a latch next to the patch lock. Release the lock while pressing the latch.

② Turn the wing nut of the filter section and remove the filter.

③ Insert a new filter and tighten the wing nut to secure.

※If the tightening is weak, fumes will leak from the outlet.

④ Attach the tank cover.

※The tank cover is divide into left and right.

※There are "L" and "R" markings on the front of the tank cover.

- 2) Replace two filters at the same time.
- 3) When you discard filter, please follow the regulations of your region.

### (3) Filter lifespan

The filter lifespan is approximately 1 year or 2,000 hours. (Varies depending on usage conditions and environment.)

※If the filter is damaged, replace it immediately regardless of its lifespan.

※If the filter is covered with the moisture of oil smoke or mist, replace it immediately regardless of its lifespan.

※If the filter lifespan has reached, but the air volume has not decreased, the replacement time can optionally delay.

#### (4) How to adjust the manometer

- 1) Make sure that the needle (black) points to "0" when the switch is off.  
If did not point to "0", adjust with the "zero adjustment knob" in Fig. 2.
- 2) When the filter is new, press the [ON] switch and check the value on the needle (black).  
The pointer position value will be at +0.5kPa, so please adjust it using the "pointer adjustment knob".

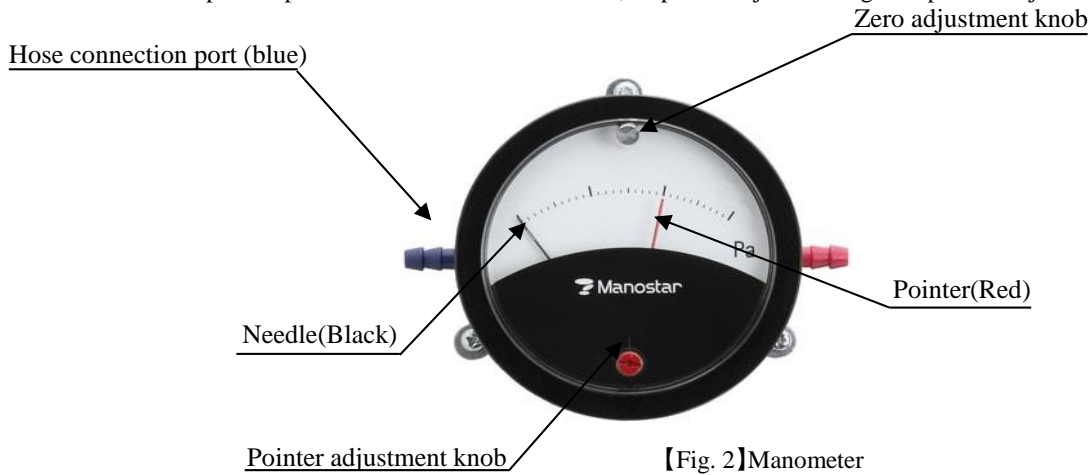

#### (5) Switch box phase change method

- 1) Turn the switch box knob and remove the cover.  
※ The wiring on the primary side and secondary side is in the order of red(R), white(W) and black (B).  
(initial stage)
- 2) Swap red and black on the primary side wiring, to this order: black, white, red.(Fig. 3)  
※ There is a yellow crossover wire at the left side of the terminal, just tighten it with the black wire.
- 3) Set the cover on the switch box and turn the knob to fix it.

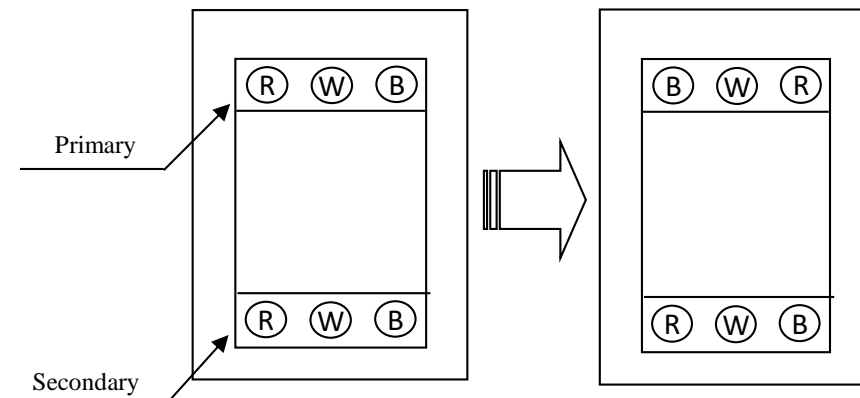

【Fig. 3】Switch box internal structure

#### (6) Another important points

- 1) If the machine will unused for a long time (more than half-year), please clean the filter.  
※ Weld fumes may stick to the filter and hardened, and will hard to remove even after cleaning.
- 2) High water or oil content in welding fumes will reduce filter lifespan significantly.
- 3) This machine filter is dry type. It cannot wash in water.
- 4) Set the air pressure for filter cleaning to **0.4 to 0.5 MPa**.

## 8. About disposal

Please follow laws and regulations when disposing of the product.

## 9. Troubleshooting

Malfunction status, situation	Probable cause and confirmation items	Safety measures and treatment
Insufficient suction power	Filter cleaning / replacement time	Please clean and replace the filter
	Product body damaged	Please (request) repair
	Clogged hood	Please remove dust and foreign matter
	Reverse phase operation	Please match the phases (see Page 5)
Manometer does not move	Hose connection failure	Please set the hose again
	Reverse phase operation	Please match the phases
	Manometer damage	Please replace the manometer
can not turn on	Plug connection failure	Please plug into the outlet properly
	Power cable disconnection	Please replace the power cable
	Loose screw in switch box	Please tighten the screw
Fume leaks	Filter installation defect	Please install properly
	Filter damage	Please replace the filter with a new one

※When the filter is new, fumes may leak from the discharge port, but this is normal

## 10. Warranty

(1) Scope of warranty

When a malfunction occurs even if operating the unit according to the instruction manual and the caution on the attachment labels, etc. within the warranty period, we will repair the failure for free.

However, if this unit is assembled into the customer's other equipment, expenses for removal from the equipment and attachment to the equipment, accompanying work expenses, transportation costs, and other indirect damages cost such as opportunity or operational loss of customers are beyond the scope of warranty.

(2) Warranty period

The warranty period shall be one year from delivery.

(3) Even within the scope of warranty, the following cases shall require charge for repair in principle.

- ① Malfunctions and damages due to wrong use contrary to the cautions in the instruction manual, attached labels, etc. or improper repair and modification.
- ② Malfunction and damages due to transportation, dropping, etc. after purchase.
- ③ Malfunctions and damages due to fires, earthquake, wind and flood damages, other disasters, abnormal voltages, use of unspecified power supply (voltage and frequency), etc.
- ④ Malfunctions and damages due to repair and modification (including drilling into the unit) by third parties.
- ⑤ Malfunction and damages due to use of parts other than those specified by us.
- ⑥ Malfunctions and damages due to mixing in offoreign materials.
- ⑦ Discoloration and flaws from age deterioration or from long-term use and malfunctions due to natural consumption of consumable parts.

(4) Damages caused by malfunctions occurring during use of this unit shall not be indemnified.

(5) The above points are specified based on use in Japan. When using this unit in countries other than Japan, consult with our branches or sales offices in advance.

## 11. Contact information

(1) Contact the following department regarding specifications and technical questions.

Showa Denki CO., LTD, Daito Factory, Business Promotion Dept.

TEL: +81-72-870-5708

FAX: +81-72-870-7243

E-mail: sales@showadenki.co.jp

(2) If the unit malfunctions or requires repair, contact our nearest sales office on the back cover. At that time, inform us of the type and manufacturing (No.) on the plate.



1-25 Shinden Kitamachi, Daito City, Osaka 574-0052

---

Oversea Sales Department

1-25 Shinden Kitamachi, Daito City, Osaka 574-0052

☎ +81-72-871-1511 FAX +81-72-870-7243

---

SHOWA DENKI (THAILAND) CO., LTD

No. 71 Soi Chalermprakit Rama 9 Soi 28, Dokmai, Prawet, Bangkok, Thailand 10250

☎ +66-2-053-1899 FAX +66-2-054-1899

---

SHOWA DENKI (KOREA) CO., LTD.

31094 A-710 Cheonan Mirae Ace High Tech City,10, Baekseokgongdan 1-ro, Seobuk-gu, Cheonan-si, Chungcheongnam-do,Korea

☎ +82-41-906-5710 FAX +82-41-906-5720

---

SHOWA DENKI (TAIWAN) CO., LTD

No.82, Liaoyang 4th Street, Beitun Dist.,Taichung City 406, Taiwan

☎ +886-4-2241-3005 FAX +886-4-2241-3006

---

<http://www.showadenki.co.jp>

CAD data is available on this website