



# Portable welding fume collector

# FUMERESA

Improve work environments  
containing welding fumes!

## S Single tank

Compact and easy to move.  
Small and powerful!  
Ideal for arc welding!!



Model:  
**FRM-H15**  
Motor output:  
**1.5 kW**



Model:  
**FRM-H37**  
Motor output:  
**3.7 kW**

## D Double tank

Large airflow and lightweight.  
Easy to move.  
Long term maintenance.  
Any kind of welding is OK!

## Outside drawing

### Single tank

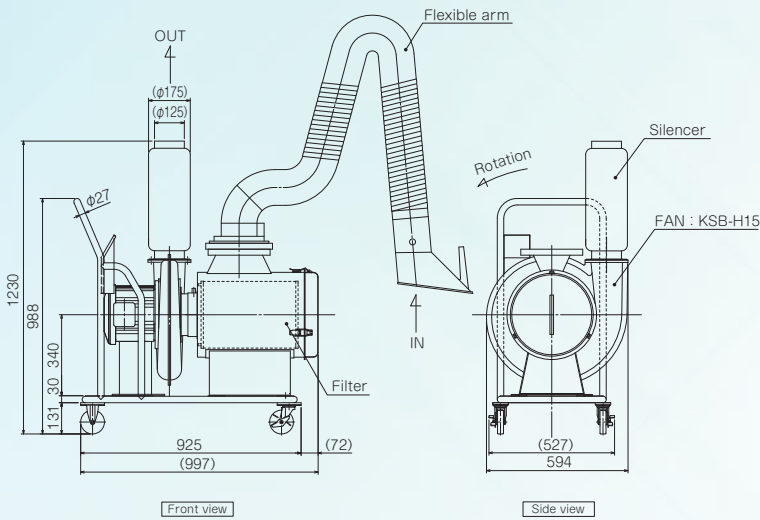

### Double tank

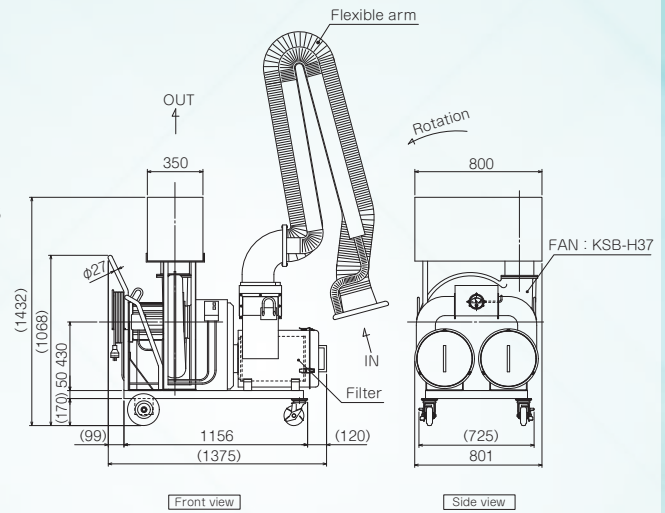

## Standard specification

	Single tank	Double tank	Remarks
Fumeresa model	FRM-H15	FRM-H37	
Suction velocity	11m/s	17m/s	The velocity will change slightly depending on the inclination of the suction duct.
Motor	1.5kW 2P	3.7kW 2P	
Voltage	200V or 380V	200V or 380V	Please confirm working voltage before you order.
Frequency	50Hz or 60Hz	50Hz or 60Hz	Please confirm working frequency before you order.
Filter	Cotton cartridge filter (1 piece)	Cotton cartridge filter (2 pieces)	
Weight	Approx. 100 kg	Approx. 150 kg	

## Application example

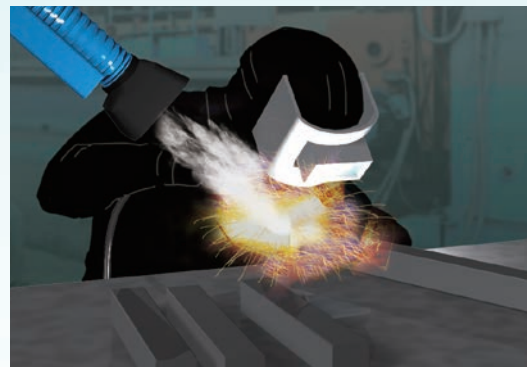

### SHOWA DENKI CO., LTD.

#### Overseas Sales Dept.

1-25 Shinden Kita-machi, Daito-city, Osaka, Japan 574-0052  
Tel: +81-72-871-1511 Fax: +81-72-870-7243  
E-mail: web-info@showadenki.co.jp

### SHOWA DENKI (KOREA) CO., LTD.

A-710 Cheonan Mirae Ace High Tech City, 10, Baekseokgongdan 1-ro, Seobuk-gu, Cheonan-si, Chungcheongnam-do, Korea  
TEL: +8241-906-5710 FAX: +8241-906-5720  
E-mail: skr@showadenki.co.jp

### SHOWA DENKI (THAILAND) CO., LTD.

No1/46 Soi2 Grande De Ville, Soi Supamong 1 (Soi Srinakarin 42), SriNakarin Road Nongbon, Pravet Bangkok, Thailand 10250  
Tel: +66-2330-8798 Fax: +66-2330-8799  
E-mail: wannapha@showadenki.co.jp  
(Japanese, Thai, English)

### SHOWA DENKI (TAIWAN) CO., LTD.

No.82, Liaoyang 4th Street, Beitun Dist., Taichung City, Taiwan  
TEL: +886-4-2241-3005 FAX: +886-4-2241-3006  
E-mail: stw@showadenki.co.jp